

TECHNICAL CATALOGUE

FULL FLOW BALL VALVES: IDEAL

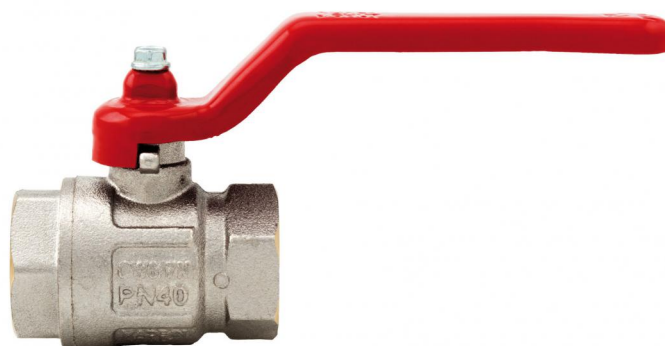

> THE COMPANY

ITAP SpA, founded in Lumezzane (Brescia) in 1972, is currently one of the leading production companies in Italy of **valves, fittings and distribution manifolds** for plumbing and heating systems.

Thanks to fully automated production processes, with 85 transfer machines and 55 assembly lines, we are able to produce 400,000 pieces per day.

Our innate pursuit for innovation and observance of technical regulations is supported by the company certification ISO 9001. The company has always considered its focus on quality as the main tool to obtain significant business results: today ITAP SpA is proud to offer products bearing the approval of numerous international certifying bodies.

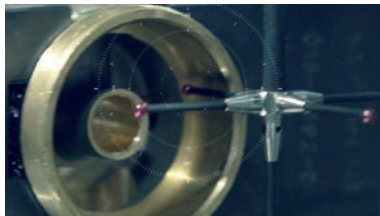
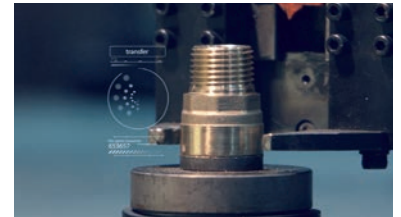
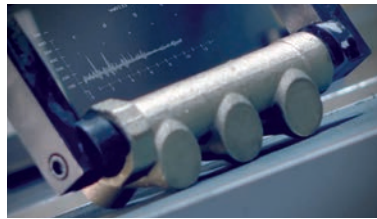
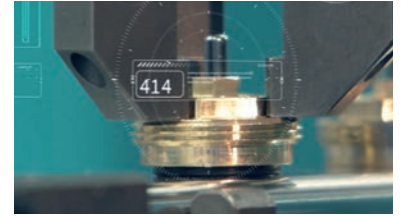
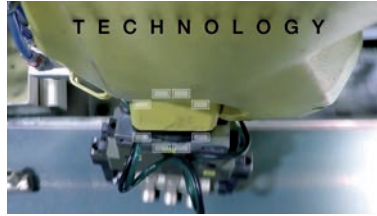

> ITAP products have obtained approvals by more than 30 certification bodies from all over the world.





FULL FLOW BALL VALVES: IDEAL

090 Ideal ball valve, full flow

Suitable for domestic water services, heating and air-conditioning plants, compressed air systems.

IDEAL



SIZE	PRESSURE	CODE	PACKING
1/4" (DN 8)	50bar/725psi	0900014/N	12/192
3/8" (DN 10)	50bar/725psi	0900038/N	12/192
1/2" (DN 15)	50bar/725psi	0900012/N	12/156
3/4" (DN 20)	40bar/580psi	0900034/N	8/64
1" (DN 25)	40bar/580psi	0900100/N	8/64
1"1/4 (DN 32)	30bar/435psi	0900114/N	4/32
1"1/2 (DN 40)	30bar/435psi	0900112/N	2/26
2" (DN 50)	25bar/362.5psi	0900200/N	2/12
2"1/2 (DN 65)	18bar/261psi	0900212/N	1/7
3" (DN 80)	16bar/232psi	0900300/N	1/4
4" (DN 100)	14bar/203psi	0900400/N	1/2

CERTIFICATIONS

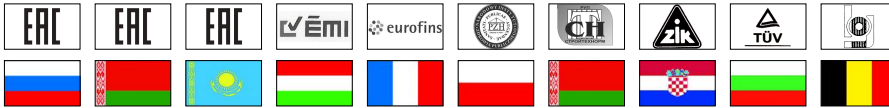

TECHNICAL SPECIFICATIONS

Female/female or male/female threads.

Lever handle in steel (aluminium in the sizes 2"1/2, 3" and 4") or T handle in aluminium or flat lever handle in lined steel.

Body in nickel-plated brass.

Minimum and maximum working temperatures: -20°C, 150°C in absence of steam.

Threads: ISO 228 (equivalent to DIN EN ISO 228 and BS EN ISO 228).

Mention "N" in the code only to order the black handle.

Available also with NPT thread in the sizes 1/4" through 2".



FULL FLOW BALL VALVES: IDEAL

OVERALL DIMENSIONS

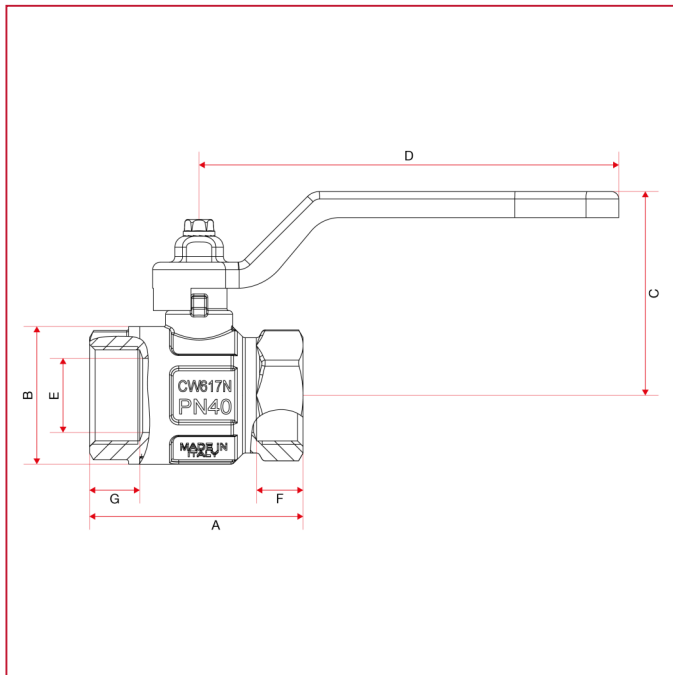

	1/4"	3/8"	1/2"	3/4"	1"	1"1/4	1"1/2	2"	2"1/2	3"	4"
DN	8	10	15	20	25	32	40	50	65	80	100
A	44,4	44,4	50,5	57,5	70	80,5	94,5	112,5	134,5	157	190
B	23,5	24	30,5	37	45,5	57	70	84	109	131	164
C	37	37	41	55	59	75	81	96	115	133	149
D	80	80	80	113	113	138	138	157,8	197	250	250
E	10	10	15	20	25	32	40	50	65	80	100
F	10	10	12	12,5	15	17	18,5	22	24	26	30
G	10	10	12,5	13,5	15	16,5	17,5	20,5	24	26	30
Kg/cm ² bar	50	50	50	40	40	30	30	25	18	16	14
LBS - psi	725	725	725	580	580	435	435	362,5	261	232	203



FULL FLOW BALL VALVES: IDEAL

MATERIALS sizes 1/4" through 2"

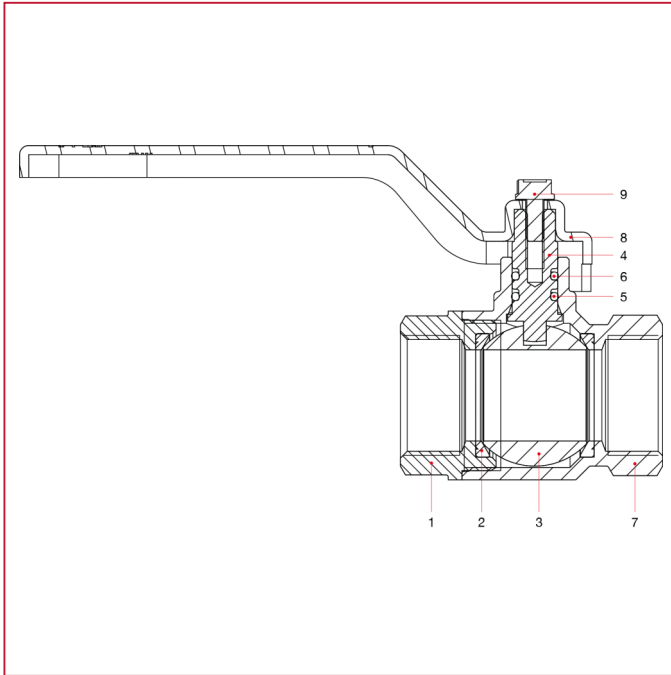

POS.	DESCRIPTION	N.	MATERIAL
1	Female end adapter	1	Nickel-plated brass CW617N
2	Seat	2	P.T.F.E.
3	Ball	1	Chrome-plated brass CW617N
4	Stem	1	Brass CW614N
5	O-ring	1	NBR
6	O-ring	1	Viton®
7	Body	1	Nickel-plated brass CW617N
8	Lever handle	1	Varnished steel P04
9	Screw	1	Zinc-plated steel C4C



FULL FLOW BALL VALVES: IDEAL

MATERIALS sizes 2"1/2 through 4"

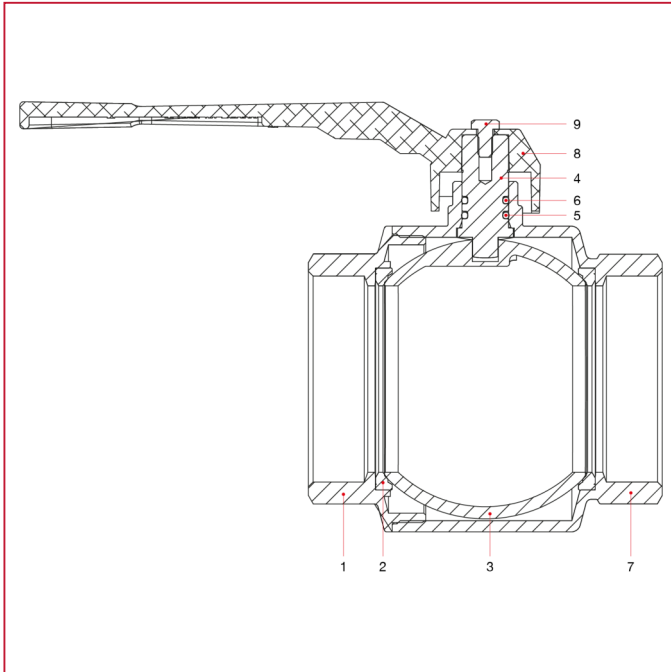

POS.	DESCRIPTION	N.	MATERIAL
1	Female end adapter	1	Nickel-plated brass CW617N
2	Seat	2	P.T.F.E.
3	Ball	1	Chrome-plated brass CW617N
4	Stem	1	Brass CW614N
5	O-ring	1	NBR
6	O-ring	1	Viton®
7	Body	1	Nickel-plated brass CW617N
8	Lever handle	1	Varnished aluminium
9	Screw	1	Zinc-plated CB4 FF (C34)



FULL FLOW BALL VALVES: IDEAL

INSTALLATION

The Itap S.p.A.'s valves are bi-directional, that means they manage the flow in both the directions.

The valves are composed by a ball, two seal in PTFE material, one stem, two sailing rings (O-Rings), one handle and a couple of parts made of brass (body and end adapter) that contain them and that are assembled by means of thread and a sealed material to obtain their aim.

In order to avoid that the sealed material gets broken and then the valve loses the connection between the body and the end-adaptor, it's necessary to avoid to submit the two parts under the influence of a torque.

For the installation normal hydraulic practices must be used, and especially:

- ones have to be sure that the two pipes are correctly aligned;
- during the assembling process the installer has to apply its assembling tools at the end that is nearest to the pipe;
- the application of the sealing materials by the fitter (PTFE or hempen cloth) must be limited at the thread zone. An excess should interfere in the ball-gasket's closure zone, compromising the tightness.
- in the case that the fluid transported presents some impurities (dust, water too hard, etc.) ones have to remove these impurities by the means of a filter. Otherwise they could damage the seals.

DISASSEMBLY

To remove the valve from the pipe line or anyhow before to unscrew the junctions linked to it:

- wear the clothing protective normally required to work with the fluid transported within the line;
- depressurize the line and operate in this way:
 - positioning the valve in opened position and then empty the line;
 - handle the valve to put down the residue pressure contained inside the space between the ball and the body before of remove it from the line;
- during the disassembly apply the screw tool at the end of the valve nearest the pipe;

MAINTENANCE

Verify the valve periodically, according to its application's field and its works' field and its work's conditions, in order to be sure that the valve works correctly.



FULL FLOW BALL VALVES: IDEAL

LOSS DIAGRAM (With water)

	1/4"	3/8"	1/2"	3/4"	1"	1"1/4"	1"1/2"	2"	2"1/2"	3"	4"
KV	3,45	5,00	15,65	26,26	41,44	63,69	101	169	348	390	725

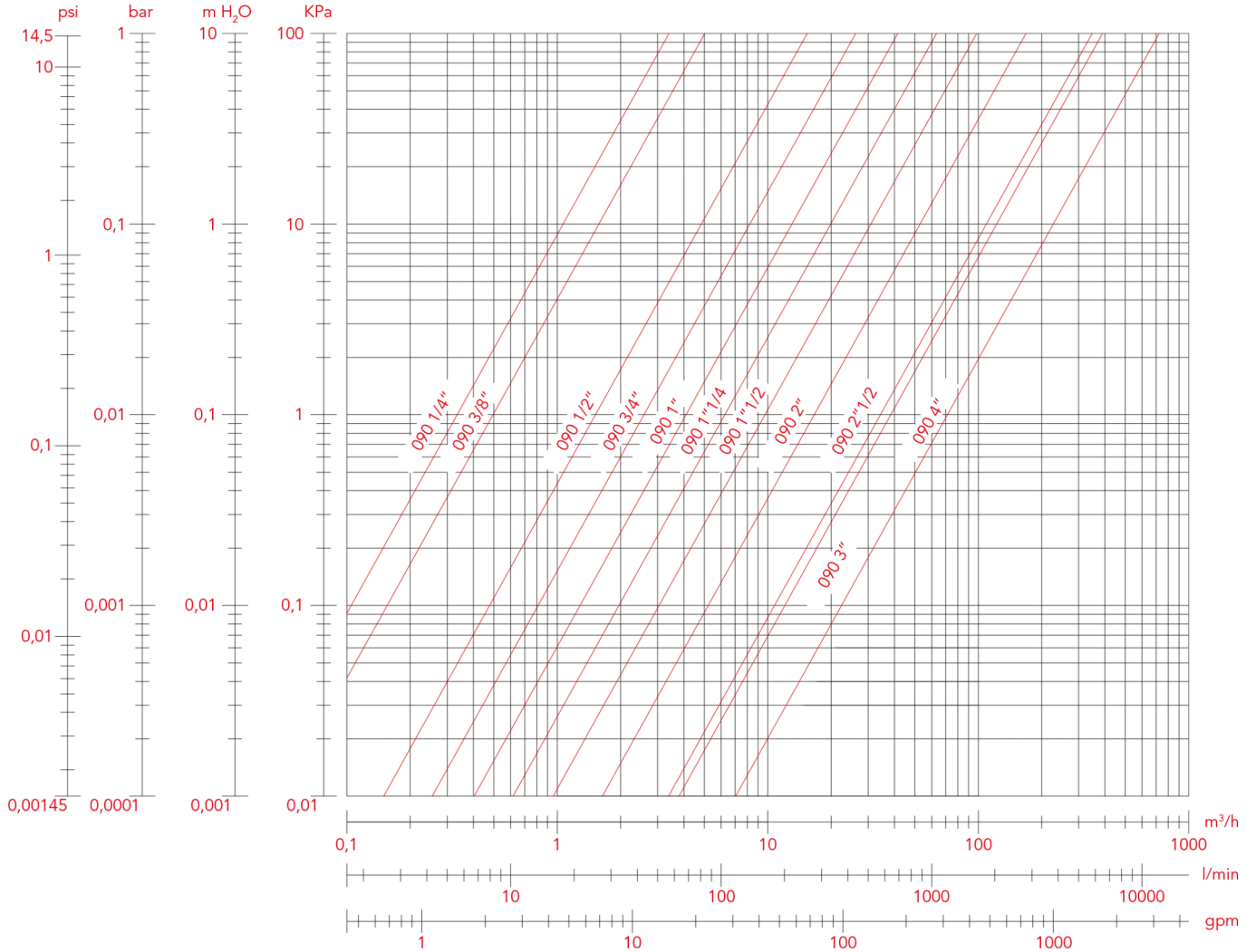



FULL FLOW BALL VALVES: IDEAL

PRESSURE-TEMPERATURE DIAGRAM

The values shown by the dropping lines state the maximum limit of employment of the valves.
The shown values are approximate.

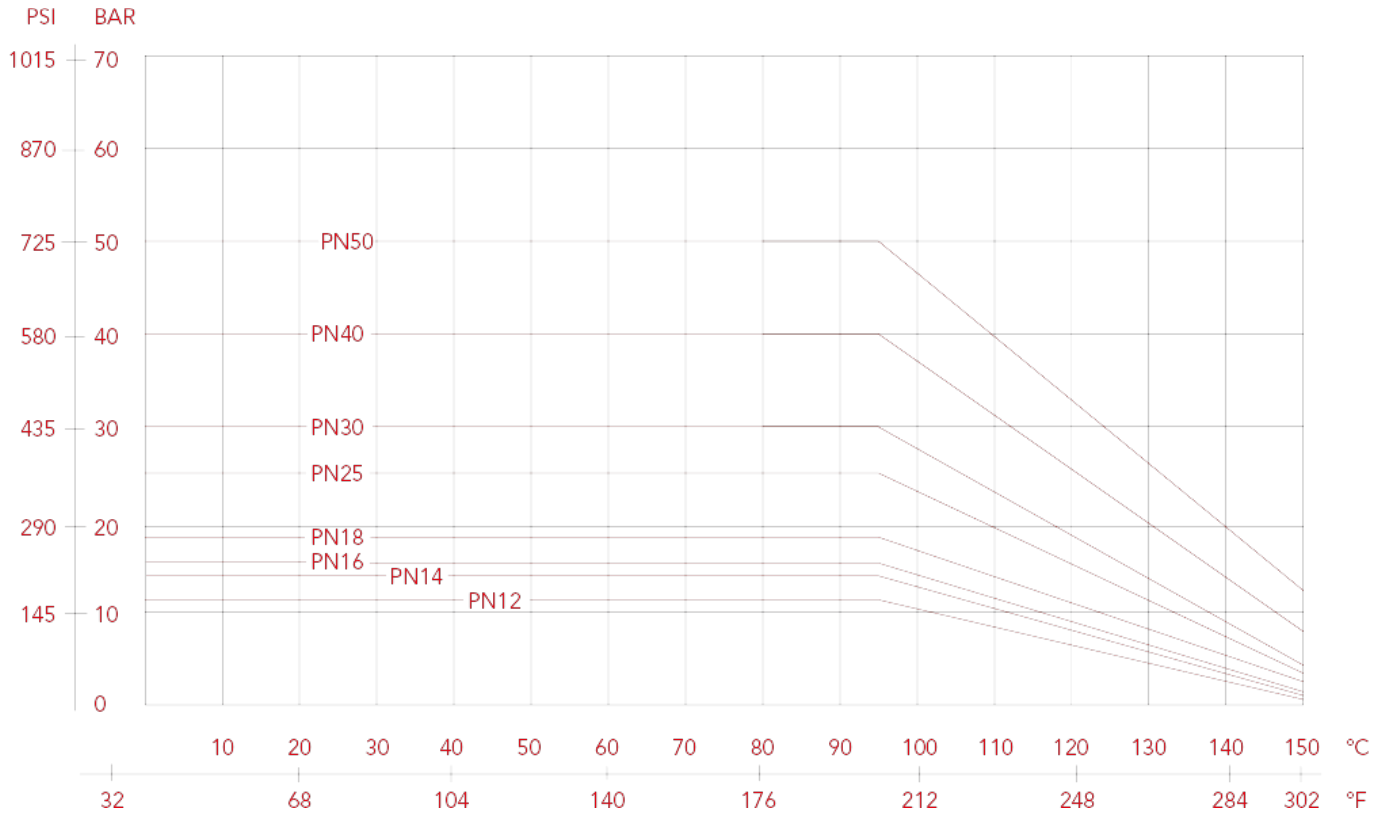



FULL FLOW BALL VALVES: IDEAL

091 Ideal ball valve, full flow

Suitable for domestic water services, heating and air-conditioning plants, compressed air systems.

IDEAL



SIZE	PRESSURE	CODE	PACKING
1/4" (DN 8)	50bar/725psi	0910014/N	12/192
3/8" (DN 10)	50bar/725psi	0910038/N	12/192
1/2" (DN 15)	50bar/725psi	0910012/N	12/120
3/4" (DN 20)	40bar/580psi	0910034/N	8/64
1" (DN 25)	40bar/580psi	0910100/N	8/40
1"1/4 (DN 32)	30bar/435psi	0910114/N	4/32
1"1/2 (DN 40)	30bar/435psi	0910112/N	2/24
2" (DN 50)	25bar/362.5psi	0910200/N	2/12

CERTIFICATIONS

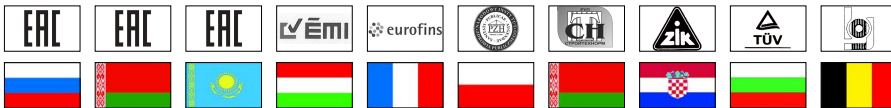

TECHNICAL SPECIFICATIONS

Female/female or male/female threads.

Lever handle in steel (aluminium in the sizes 2"1/2, 3" and 4") or T handle in aluminium or flat lever handle in lined steel.

Body in nickel-plated brass.

Minimum and maximum working temperatures: -20°C, 150°C in absence of steam.

Threads: ISO 228 (equivalent to DIN EN ISO 228 and BS EN ISO 228).

Mention "N" in the code only to order the black handle.



FULL FLOW BALL VALVES: IDEAL

OVERALL DIMENSIONS

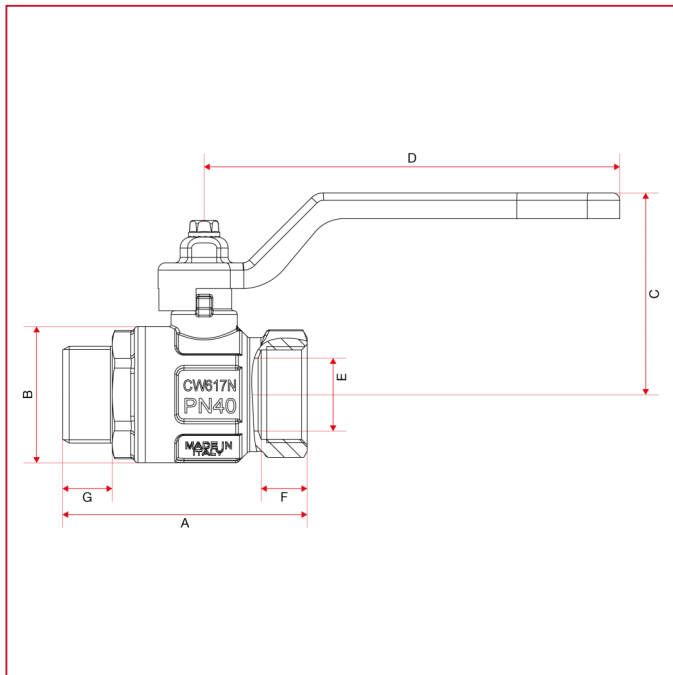

	1/4"	3/8"	1/2"	3/4"	1"	1"1/4	1"1/2	2"
DN	8	10	15	20	25	32	40	50
A	54	54	58,5	66,5	78,5	91,5	105,5	122
B	23,5	24	30,5	37	45,5	57	70	84
C	37	37	41	55	59	75	81	96
D	80	80	80	113	113	138	138	157,8
E	8	10	15	20	25	32	39	50
F	10	10	12	12,5	15	17	18,5	22
G	10,5	10,5	11,5	13,5	14,5	17	19	21
Kg/cm2 bar	50	50	50	40	40	30	30	25
LBS - psi	725	725	725	580	580	435	435	362,5



FULL FLOW BALL VALVES: IDEAL

MATERIALS

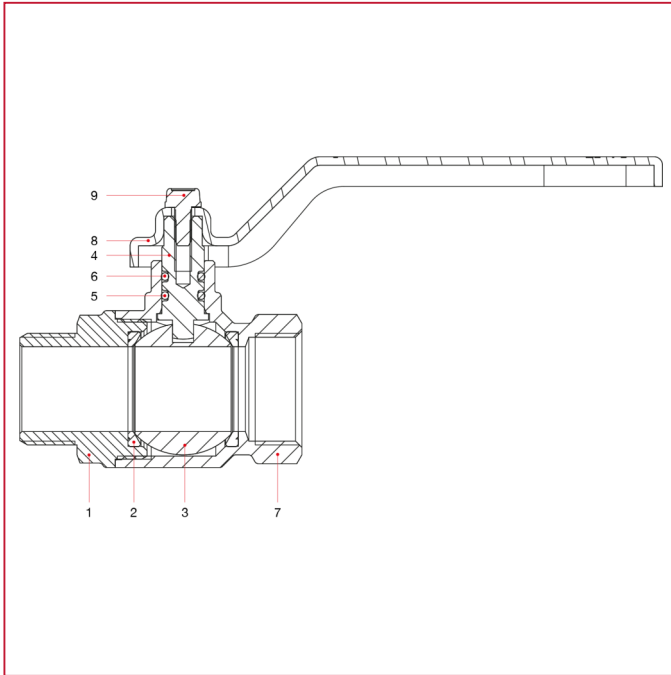

POS.	DESCRIPTION	N.	MATERIAL
1	Male end adapter	1	Nickel-plated brass CW617N
2	Seat	2	P.T.F.E.
3	Ball	1	Chrome-plated brass CW617N
4	Stem	1	Brass CW614N
5	O-ring	1	NBR
6	O-ring	1	Viton®
7	Body	1	Nickel-plated brass CW617N
8	Lever handle	1	Varnished steel P04
9	Screw	1	Zinc-plated steel C4C



FULL FLOW BALL VALVES: IDEAL

INSTALLATION

The Itap S.p.A.'s valves are bi-directional, that means they manage the flow in both the directions.

The valves are composed by a ball, two seal in PTFE material, one stem, two sailing rings (O-Rings), one handle and a couple of parts made of brass (body and end adapter) that contain them and that are assembled by means of thread and a sealed material to obtain their aim.

In order to avoid that the sealed material gets broken and then the valve loses the connection between the body and the end-adaptor, it's necessary to avoid to submit the two parts under the influence of a torque.

For the installation normal hydraulic practices must be used, and especially:

- ones have to be sure that the two pipes are correctly aligned;
- during the assembling process the installer has to apply its assembling tools at the end that is nearest to the pipe;
- the application of the sealing materials by the fitter (PTFE or hempen cloth) must be limited at the thread zone. An excess should interfere in the ball-gasket's closure zone, compromising the tightness.
- in the case that the fluid transported presents some impurities (dust, water too hard, etc.) ones have to remove these impurities by the means of a filter. Otherwise they could damage the seals.

DISASSEMBLY

To remove the valve from the pipe line or anyhow before to unscrew the junctions linked to it:

- wear the clothing protective normally required to work with the fluid transported within the line;
- depressurize the line and operate in this way:
 - positioning the valve in opened position and then empty the line;
 - handle the valve to put down the residue pressure contained inside the space between the ball and the body before of remove it from the line;
- during the disassembly apply the screw tool at the end of the valve nearest the pipe;

MAINTENANCE

Verify the valve periodically, according to its application's field and its works' field and its work's conditions, in order to be sure that the valve works correctly.



FULL FLOW BALL VALVES: IDEAL

LOSS DIAGRAM (With water)

	1/4"	3/8"	1/2"	3/4"	1"	1"1/4"	1"1/2"	2"
KV	3,45	5,00	15,65	26,26	41,44	63,69	101	169

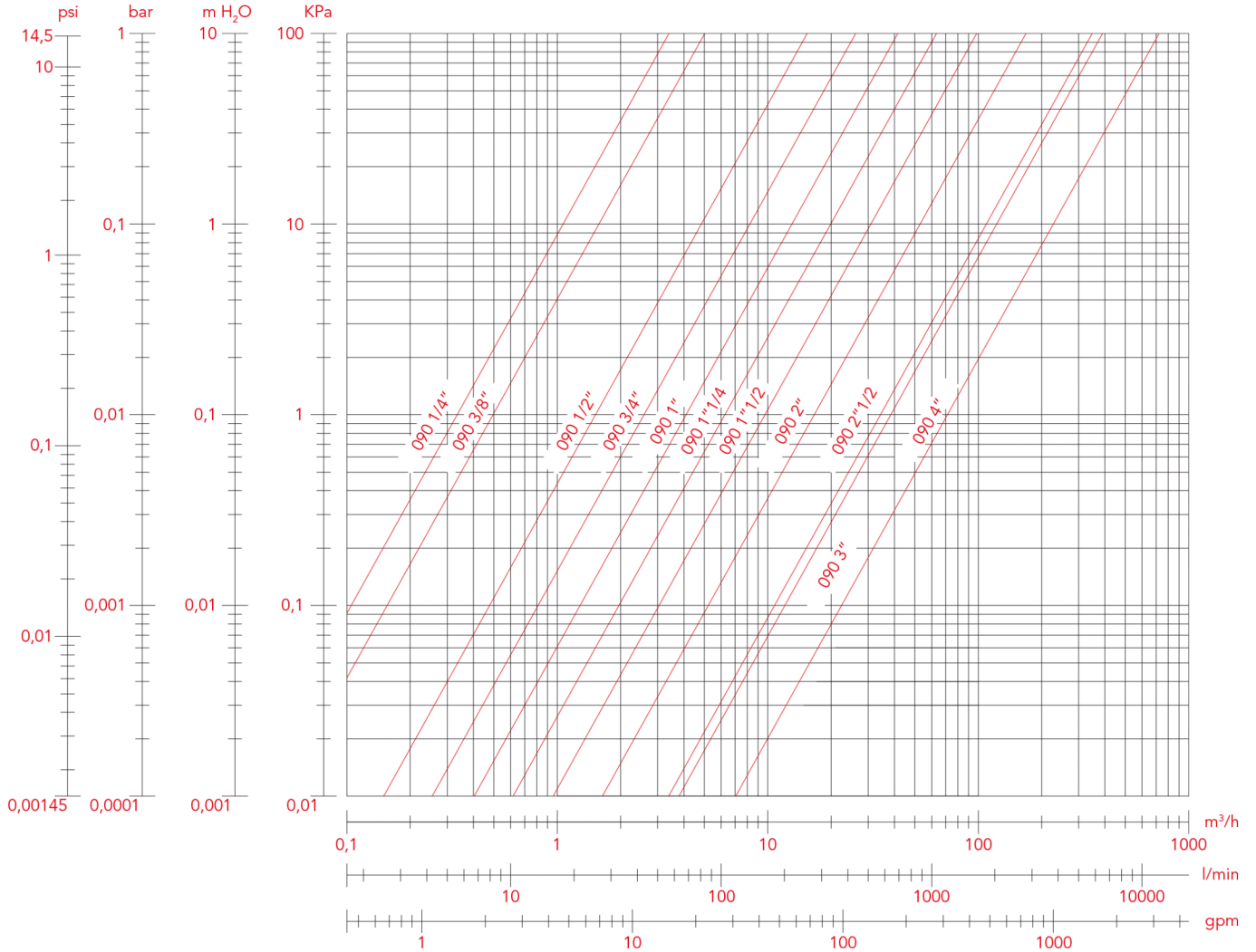



FULL FLOW BALL VALVES: IDEAL

PRESSURE-TEMPERATURE DIAGRAM

The values shown by the dropping lines state the maximum limit of employment of the valves.
The shown values are approximate.

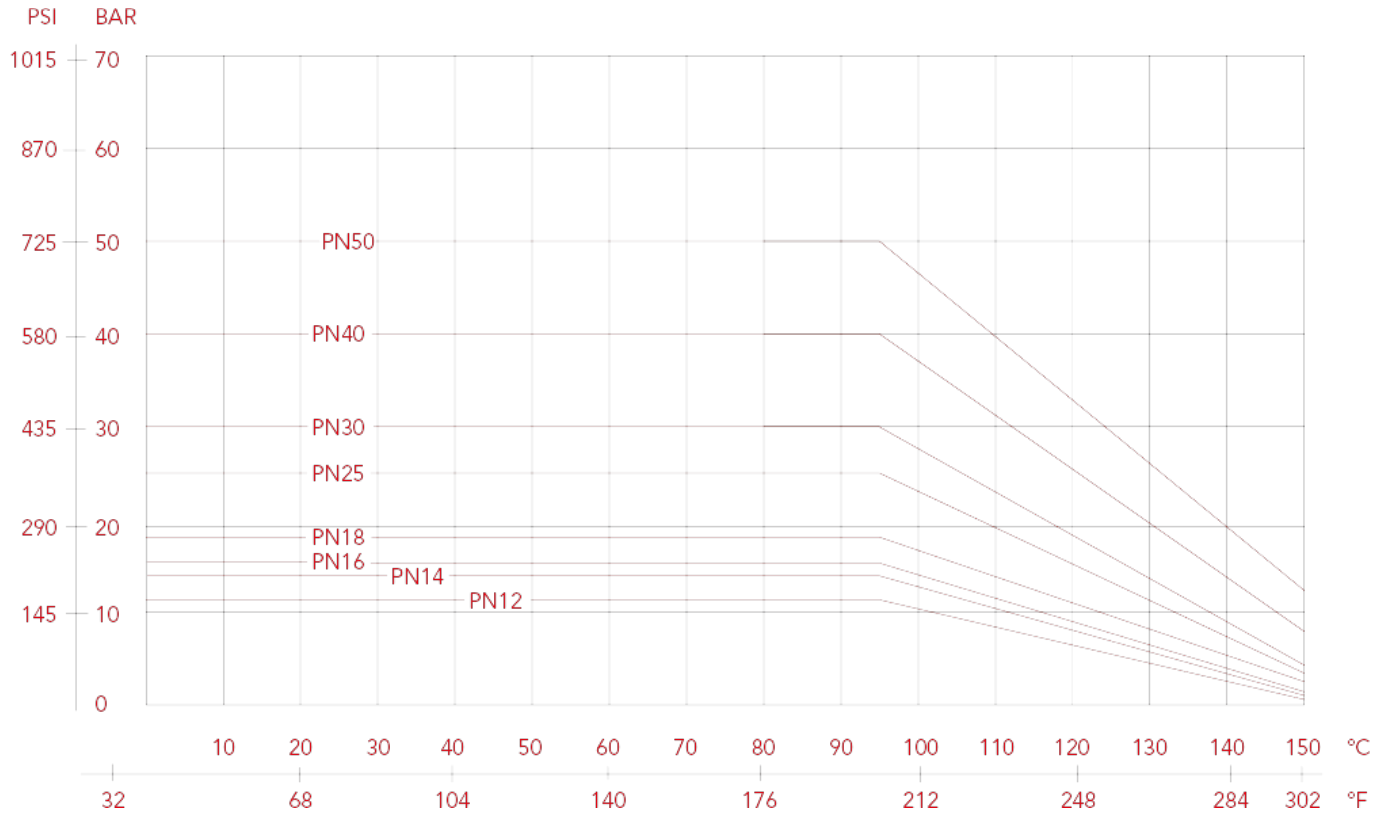



FULL FLOW BALL VALVES: IDEAL

092 Ideal ball valve, full flow

Suitable for domestic water services, heating and air-conditioning plants, compressed air systems.

IDEAL



SIZE	PRESSURE	CODE	PACKING
1/4" (DN 8)	50bar/725psi	0920014/N	15/240
3/8" (DN 10)	50bar/725psi	0920038/N	15/240
1/2" (DN 15)	50bar/725psi	0920012/N	12/132
3/4" (DN 20)	40bar/580psi	0920034/N	8/88
1" (DN 25)	40bar/580psi	0920100/N	8/64
1 1/4" (DN 32)	30bar/435psi	0920114/N	4/32

CERTIFICATIONS

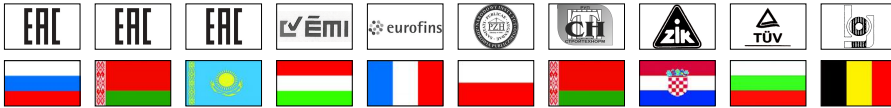

TECHNICAL SPECIFICATIONS

Female/female or male/female threads.

Lever handle in steel (aluminium in the sizes 2 1/2", 3" and 4") or T handle in aluminium or flat lever handle in lined steel.

Body in nickel-plated brass.

Minimum and maximum working temperatures: -20°C, 150°C in absence of steam.

Threads: ISO 228 (equivalent to DIN EN ISO 228 and BS EN ISO 228).

Mention "N" in the code only to order the black handle.

Available also with NPT thread in the sizes 1/4" through 1".



FULL FLOW BALL VALVES: IDEAL

OVERALL DIMENSIONS

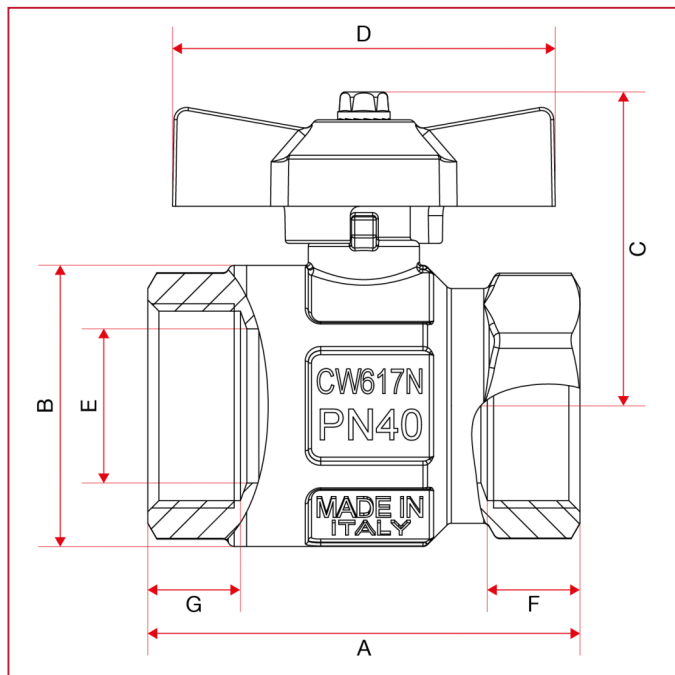

	1/4"	3/8"	1/2"	3/4"	1"	1"1/4
DN	8	10	15	20	25	32
A	44,4	44,4	50,5	57,5	70	80,5
B	23,5	24	30,5	37	45,5	57
C	37	37	41	47	51	64
D	47	47	47	62	62	70
E	10	10	15	20	25	32
F	10	10	12	12,5	15	17
G	10	10	12,5	13,5	15	16,5
Kg/cm2 bar	50	50	50	40	40	30
LBS - psi	725	725	725	580	580	435



FULL FLOW BALL VALVES: IDEAL

MATERIALS

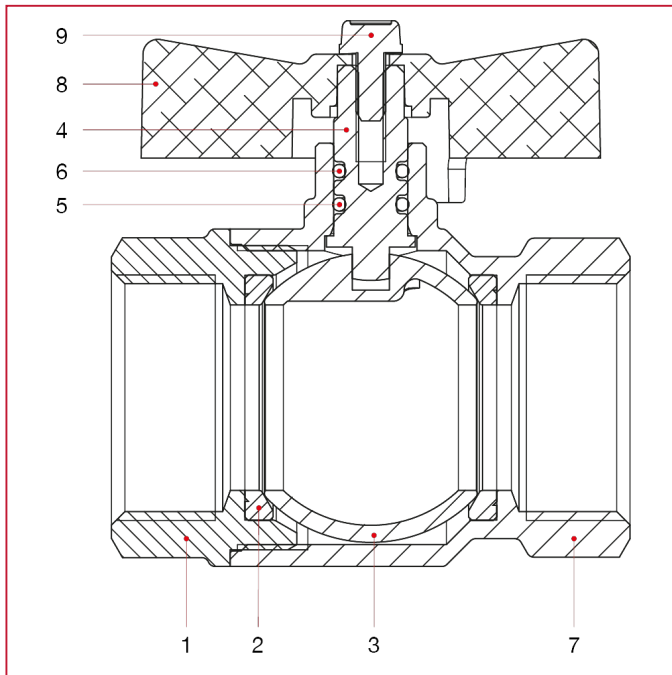

POS.	DESCRIPTION	N.	MATERIAL
1	Female end adapter	1	Nickel-plated brass CW617N
2	Seat	2	P.T.F.E.
3	Ball	1	Chrome-plated brass CW617N
4	Stem	1	Brass CW614N
5	O-ring	1	NBR
6	O-ring	1	Viton®
7	Body	1	Nickel-plated brass CW617N
8	T handle	1	Varnished aluminium
9	Screw	1	Zinc-plated steel C4C



FULL FLOW BALL VALVES: IDEAL

INSTALLATION

The Itap S.p.A.'s valves are bi-directional, that means they manage the flow in both the directions.

The valves are composed by a ball, two seal in PTFE material, one stem, two sailing rings (O-Rings), one handle and a couple of parts made of brass (body and end adapter) that contain them and that are assembled by means of thread and a sealed material to obtain their aim.

In order to avoid that the sealed material gets broken and then the valve loses the connection between the body and the end-adaptor, it's necessary to avoid to submit the two parts under the influence of a torque.

For the installation normal hydraulic practices must be used, and especially:

- ones have to be sure that the two pipes are correctly aligned;
- during the assembling process the installer has to apply its assembling tools at the end that is nearest to the pipe;
- the application of the sealing materials by the fitter (PTFE or hempen cloth) must be limited at the thread zone. An excess should interfere in the ball-gasket's closure zone, compromising the tightness.
- in the case that the fluid transported presents some impurities (dust, water too hard, etc.) ones have to remove these impurities by the means of a filter. Otherwise they could damage the seals.

DISASSEMBLY

To remove the valve from the pipe line or anyhow before to unscrew the junctions linked to it:

- wear the clothing protective normally required to work with the fluid transported within the line;
- depressurize the line and operate in this way:
 - positioning the valve in opened position and then empty the line;
 - handle the valve to put down the residue pressure contained inside the space between the ball and the body before of remove it from the line;
- during the disassembly apply the screw tool at the end of the valve nearest the pipe;

MAINTENANCE

Verify the valve periodically, according to its application's field and its works' field and its work's conditions, in order to be sure that the valve works correctly.



FULL FLOW BALL VALVES: IDEAL

LOSS DIAGRAM (With water)

	1/4"	3/8"	1/2"	3/4"	1"	1 1/4"
KV	3,45	5,00	15,65	26,26	41,44	63,69

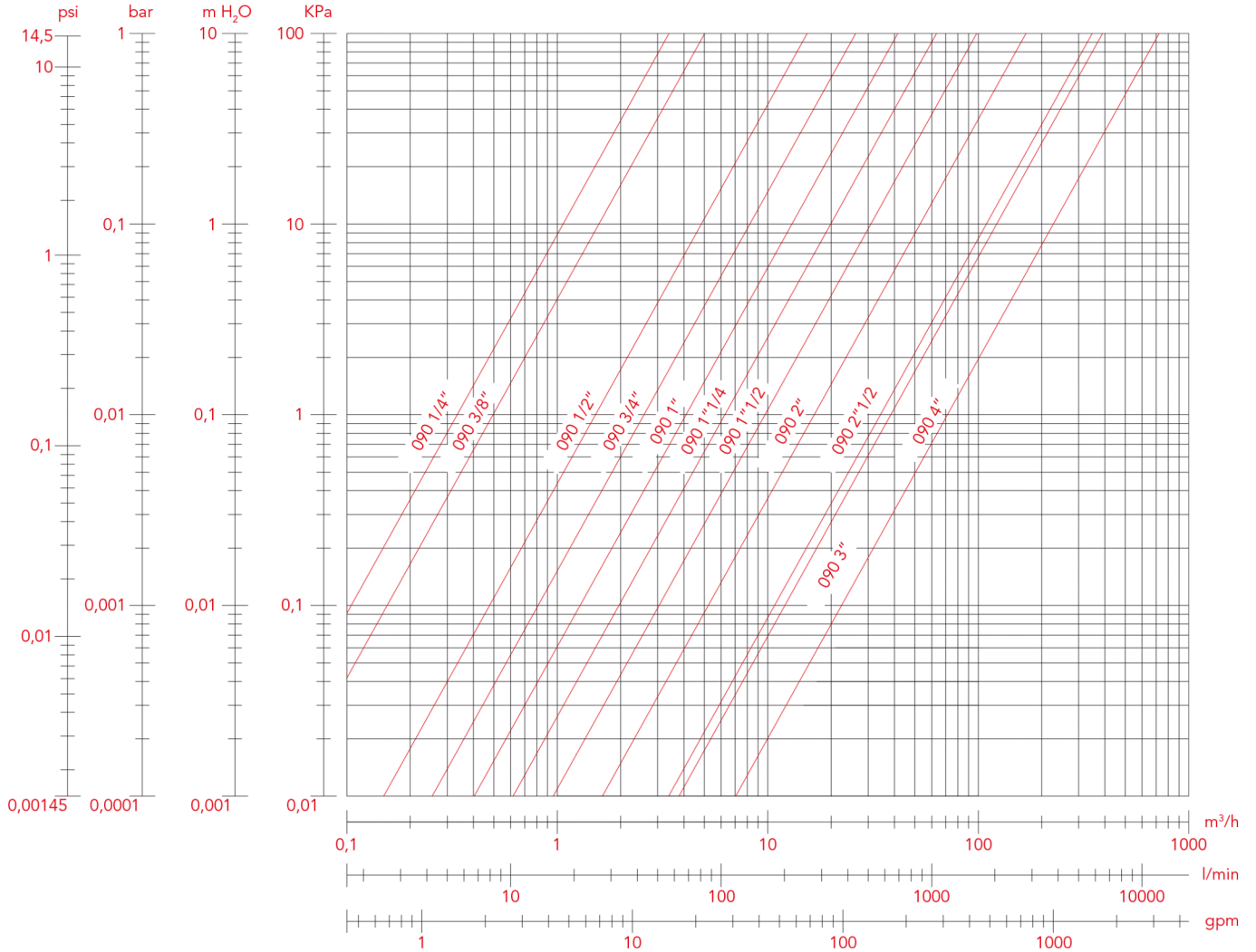



FULL FLOW BALL VALVES: IDEAL

PRESSURE-TEMPERATURE DIAGRAM

The values shown by the dropping lines state the maximum limit of employment of the valves.
The shown values are approximate.

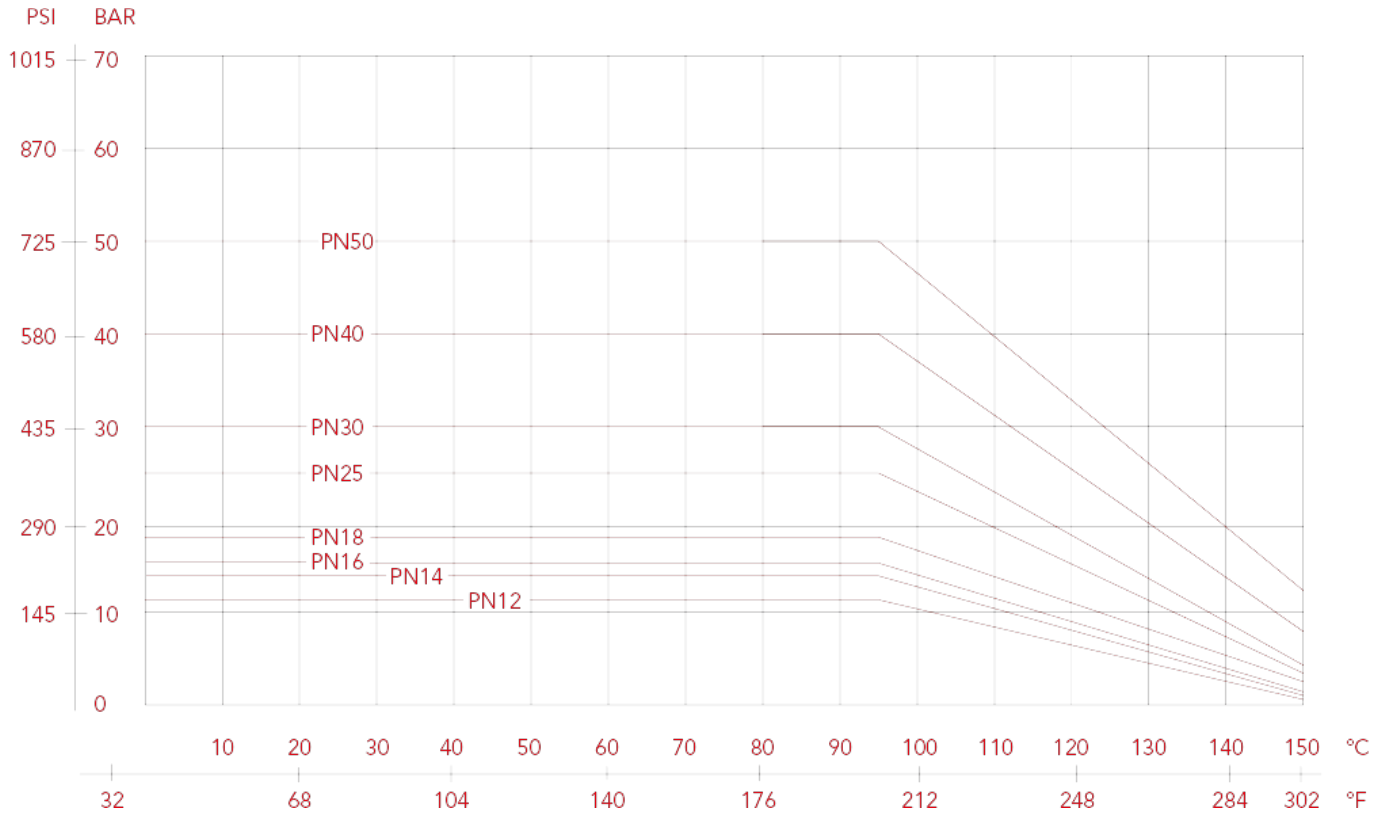



FULL FLOW BALL VALVES: IDEAL

093 Ideal ball valve, full flow

Suitable for domestic water services, heating and air-conditioning plants, compressed air systems.

IDEAL

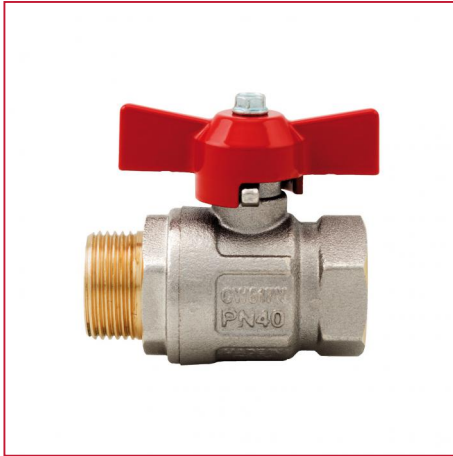

SIZE	PRESSURE	CODE	PACKING
1/4" (DN 8)	50bar/725psi	0930014/N	15/165
3/8" (DN 10)	50bar/725psi	0930038/N	15/165
1/2" (DN 15)	50bar/725psi	0930012/N	12/96
3/4" (DN 20)	40bar/580psi	0930034/N	8/64
1" (DN 25)	40bar/580psi	0930100/N	8/64
1 1/4" (DN 32)	30bar/435psi	0930114/N	4/32

CERTIFICATIONS

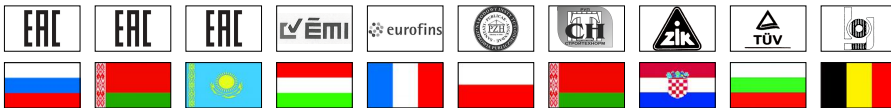

TECHNICAL SPECIFICATIONS

Female/female or male/female threads.

Lever handle in steel (aluminium in the sizes 2"1/2, 3" and 4") or T handle in aluminium or flat lever handle in lined steel.

Body in nickel-plated brass.

Minimum and maximum working temperatures: -20°C, 150°C in absence of steam.

Threads: ISO 228 (equivalent to DIN EN ISO 228 and BS EN ISO 228).

Mention "N" in the code only to order the black handle.



FULL FLOW BALL VALVES: IDEAL

OVERALL DIMENSIONS

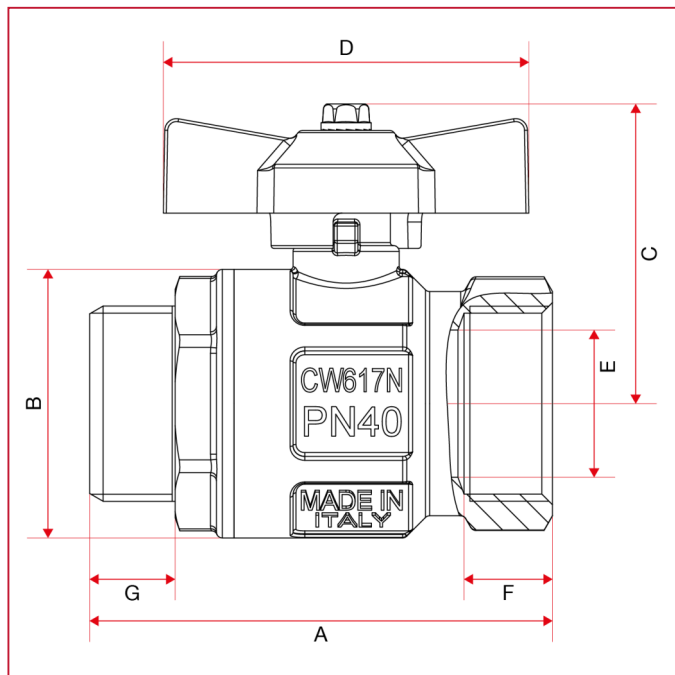

	1/4"	3/8"	1/2"	3/4"	1"	1"1/4
DN	8	10	15	20	25	32
A	54	54	58,5	66,5	78,5	91,5
B	23,5	24	30,5	37	45,5	57
C	37	37	41	47	51	64
D	47	47	47	62	62	70
E	8	10	15	20	25	32
F	10	10	12	12,5	15	17
G	10,5	10,5	11,5	13,5	14,5	17
Kg/cm ² bar	50	50	50	40	40	30
LBS - psi	725	725	725	580	580	435



FULL FLOW BALL VALVES: IDEAL

MATERIALS

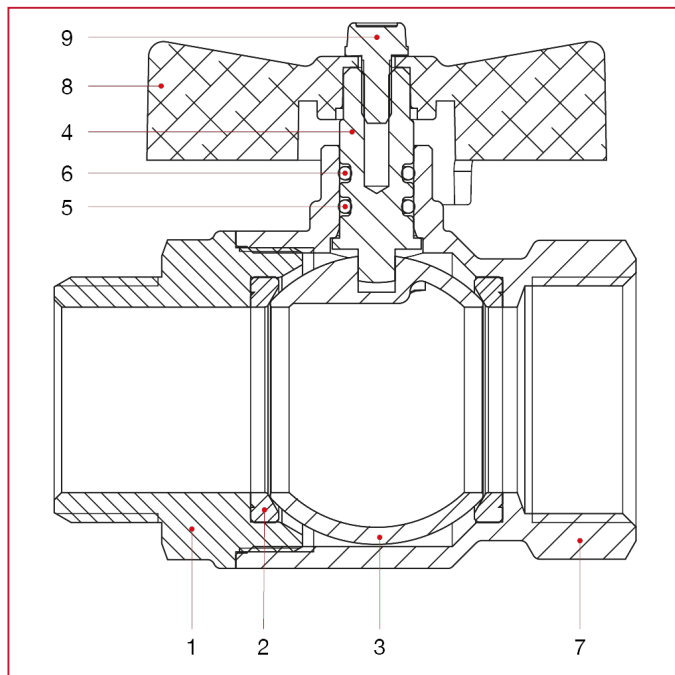

POS.	DESCRIPTION	N.	MATERIAL
1	Male end adapter	1	Nickel-plated brass CW617N
2	Seat	2	P.T.F.E.
3	Ball	1	Chrome-plated brass CW617N
4	Stem	1	Brass CW614N
5	O-ring	1	NBR
6	O-ring	1	Viton®
7	Body	1	Nickel-plated brass CW617N
8	T handle	1	Varnished aluminium
9	Screw	1	Zinc-plated steel C4C



FULL FLOW BALL VALVES: IDEAL

INSTALLATION

The Itap S.p.A.'s valves are bi-directional, that means they manage the flow in both the directions.

The valves are composed by a ball, two seal in PTFE material, one stem, two sailing rings (O-Rings), one handle and a couple of parts made of brass (body and end adapter) that contain them and that are assembled by means of thread and a sealed material to obtain their aim.

In order to avoid that the sealed material gets broken and then the valve loses the connection between the body and the end-adaptor, it's necessary to avoid to submit the two parts under the influence of a torque.

For the installation normal hydraulic practices must be used, and especially:

- ones have to be sure that the two pipes are correctly aligned;
- during the assembling process the installer has to apply its assembling tools at the end that is nearest to the pipe;
- the application of the sealing materials by the fitter (PTFE or hempen cloth) must be limited at the thread zone. An excess should interfere in the ball-gasket's closure zone, compromising the tightness.
- in the case that the fluid transported presents some impurities (dust, water too hard, etc.) ones have to remove these impurities by the means of a filter. Otherwise they could damage the seals.

DISASSEMBLY

To remove the valve from the pipe line or anyhow before to unscrew the junctions linked to it:

- wear the clothing protective normally required to work with the fluid transported within the line;
- depressurize the line and operate in this way:
 - positioning the valve in opened position and then empty the line;
 - handle the valve to put down the residue pressure contained inside the space between the ball and the body before of remove it from the line;
- during the disassembly apply the screw tool at the end of the valve nearest the pipe;

MAINTENANCE

Verify the valve periodically, according to its application's field and its works' field and its work's conditions, in order to be sure that the valve works correctly.



FULL FLOW BALL VALVES: IDEAL

LOSS DIAGRAM (With water)

	1/4"	3/8"	1/2"	3/4"	1"	1 1/4"
KV	3,45	5,00	15,65	26,26	41,44	63,69

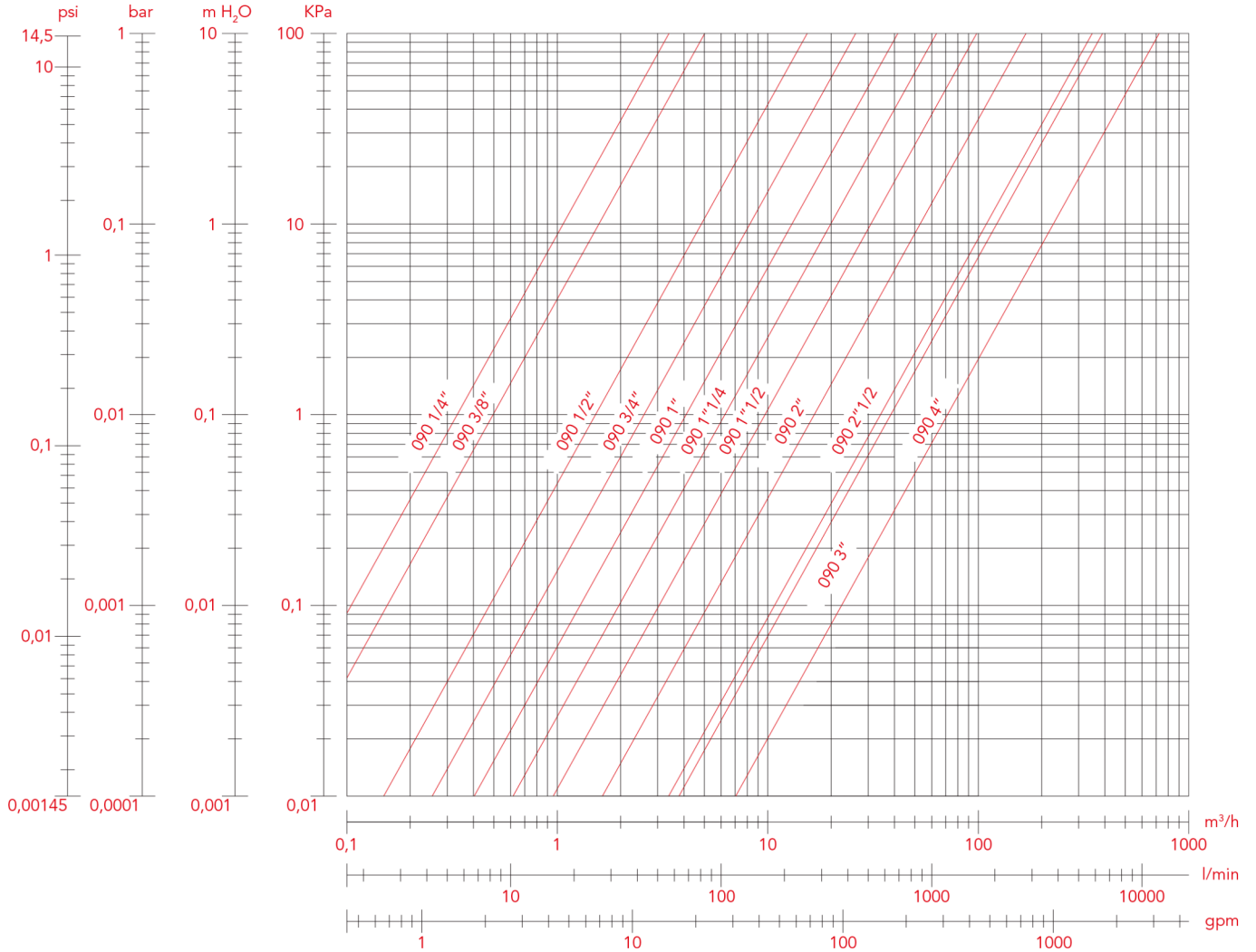



FULL FLOW BALL VALVES: IDEAL

PRESSURE-TEMPERATURE DIAGRAM

The values shown by the dropping lines state the maximum limit of employment of the valves.
The shown values are approximate.

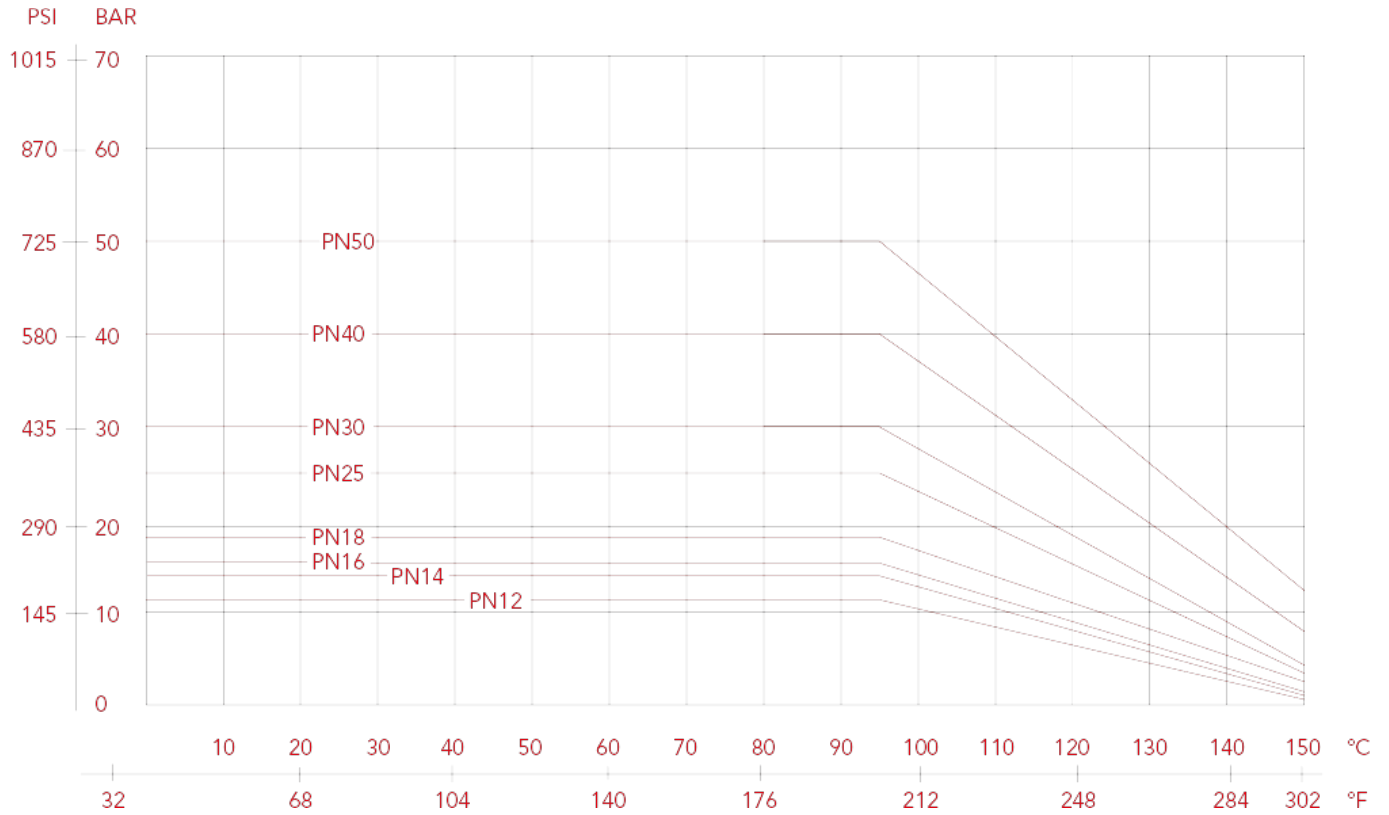



FULL FLOW BALL VALVES: IDEAL

290 Ideal ball valve, full flow

Suitable for domestic water services, heating and air-conditioning plants, compressed air systems.

IDEAL



SIZE	PRESSURE	CODE	PACKING
1/4" (DN 8)	50bar/725psi	2160014	12/192
3/8" (DN 10)	50bar/725psi	2160038	12/192
1/2" (DN 15)	50bar/725psi	2900012	12/120
3/4" (DN 20)	40bar/580psi	2900034	8/64
1" (DN 25)	40bar/580psi	2900100	6/48
1"1/4 (DN 32)	30bar/435psi	2900114	4/32
1"1/2 (DN 40)	30bar/435psi	2900112	2/24
2" (DN 50)	25bar/362.5psi	2900200	2/12

CERTIFICATIONS

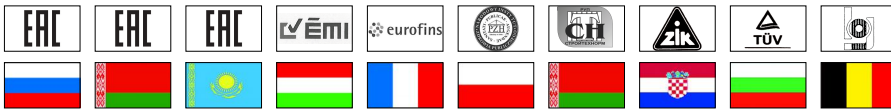

TECHNICAL SPECIFICATIONS

Female/female or male/female threads.

Lever handle in steel (aluminium in the sizes 2"1/2, 3" and 4") or T handle in aluminium or flat lever handle in lined steel.

Body in nickel-plated brass.

Minimum and maximum working temperatures: -20°C, 150°C in absence of steam.

Threads: ISO 228 (equivalent to DIN EN ISO 228 and BS EN ISO 228).

OVERALL DIMENSIONS

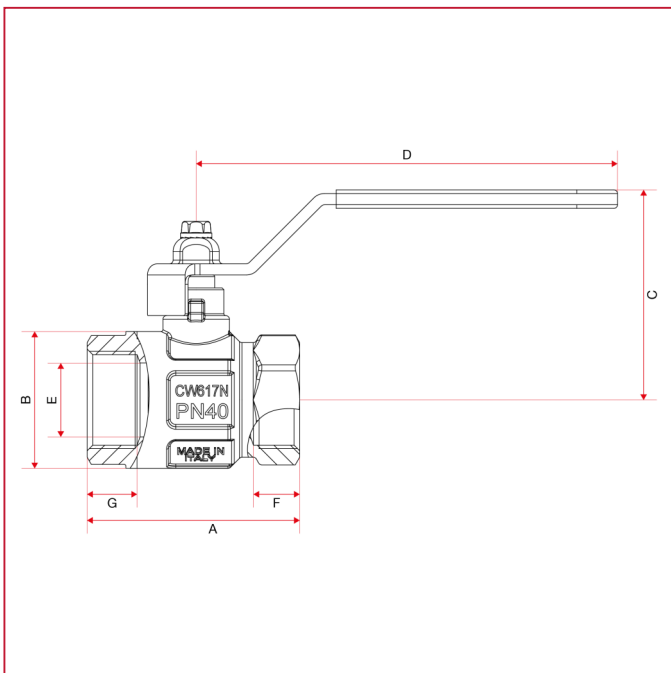



FULL FLOW BALL VALVES: IDEAL

	1/4"	3/8"	1/2"	3/4"	1"	1"1/4	1"1/2	2"
DN	8	10	15	20	25	32	40	50
A	44,4	44,4	50,5	57,5	70	80,5	94,5	112,5
B	23,5	24	30,5	37	45,5	57	70	84
C	42,3	42,3	46,3	56,8	60,8	76,3	82,5	98,3
D	86	86	86	114	114	138,5	138,5	158,5
E	10	10	15	20	25	32	40	50
F	10	10	12	12,5	15	17	18	22
G	10		12,5	13,5	15	16,5	17,5	20,5
Kg/cm2 bar	50	50	50	40	40	30	30	25
LBS - psi	725	725	725	580	580	435	435	362,5

MATERIALS

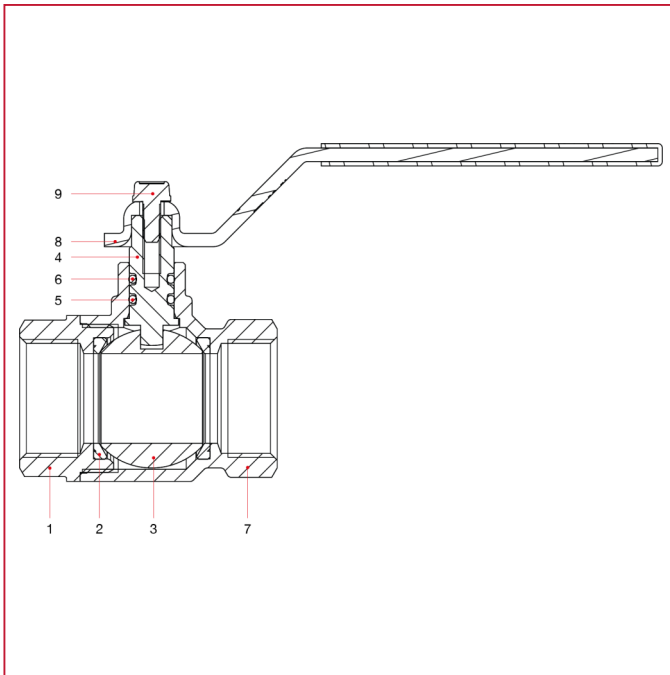

POS.	DESCRIPTION	N.	MATERIAL
1	Female end adapter	1	Nickel-plated brass CW617N
2	Seat	2	P.T.F.E.
3	Ball	1	Chrome-plated brass CW617N
4	Stem	1	Brass CW614N
5	O-ring	1	NBR
6	O-ring	1	Viton®
7	Body	1	Nickel-plated brass CW617N
8	Flat lever handle	1	Zinc-plated and plastic coated steel P04
9	Screw	1	Zinc-plated steel C4C



FULL FLOW BALL VALVES: IDEAL

INSTALLATION

The Itap S.p.A.'s valves are bi-directional, that means they manage the flow in both the directions.

The valves are composed by a ball, two seal in PTFE material, one stem, two sailing rings (O-Rings), one handle and a couple of parts made of brass (body and end adapter) that contain them and that are assembled by means of thread and a sealed material to obtain their aim.

In order to avoid that the sealed material gets broken and then the valve loses the connection between the body and the end-adaptor, it's necessary to avoid to submit the two parts under the influence of a torque.

For the installation normal hydraulic practices must be used, and especially:

- ones have to be sure that the two pipes are correctly aligned;
- during the assembling process the installer has to apply its assembling tools at the end that is nearest to the pipe;
- the application of the sealing materials by the fitter (PTFE or hempen cloth) must be limited at the thread zone. An excess should interfere in the ball-gasket's closure zone, compromising the tightness.
- in the case that the fluid transported presents some impurities (dust, water too hard, etc.) ones have to remove these impurities by the means of a filter. Otherwise they could damage the seals.

DISASSEMBLY

To remove the valve from the pipe line or anyhow before to unscrew the junctions linked to it:

- wear the clothing protective normally required to work with the fluid transported within the line;
- depressurize the line and operate in this way:
 - positioning the valve in opened position and then empty the line;
 - handle the valve to put down the residue pressure contained inside the space between the ball and the body before of remove it from the line;
- during the disassembly apply the screw tool at the end of the valve nearest the pipe;

MAINTENANCE

Verify the valve periodically, according to its application's field and its works' field and its work's conditions, in order to be sure that the valve works correctly.



FULL FLOW BALL VALVES: IDEAL

LOSS DIAGRAM (With water)

	1/4"	3/8"	1/2"	3/4"	1"	1"1/4"	1"1/2"	2"
KV	3,33	4,92	15,65	26,26	41,44	63,69	101	169

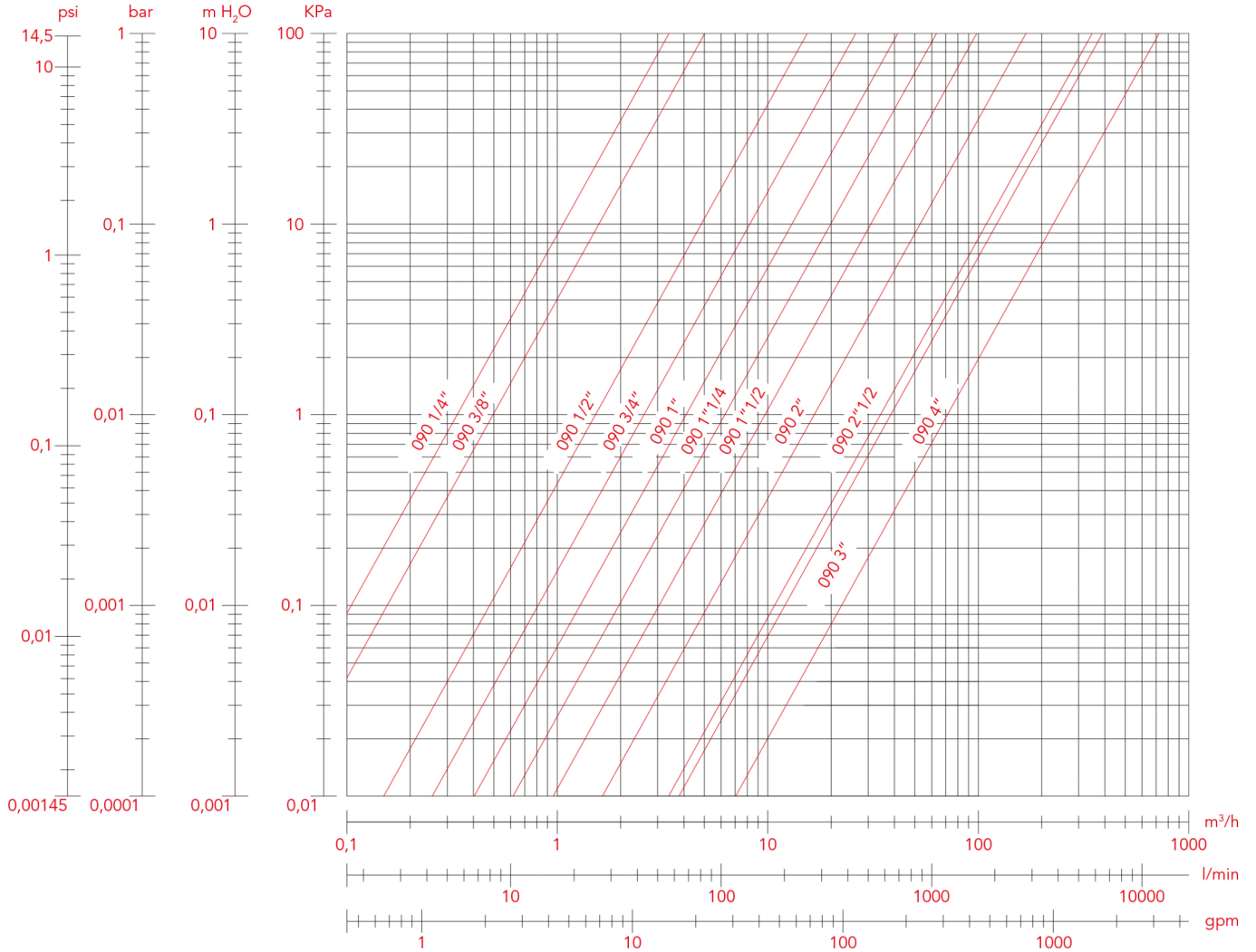



FULL FLOW BALL VALVES: IDEAL

PRESSURE-TEMPERATURE DIAGRAM

The values shown by the dropping lines state the maximum limit of employment of the valves.
The shown values are approximate.

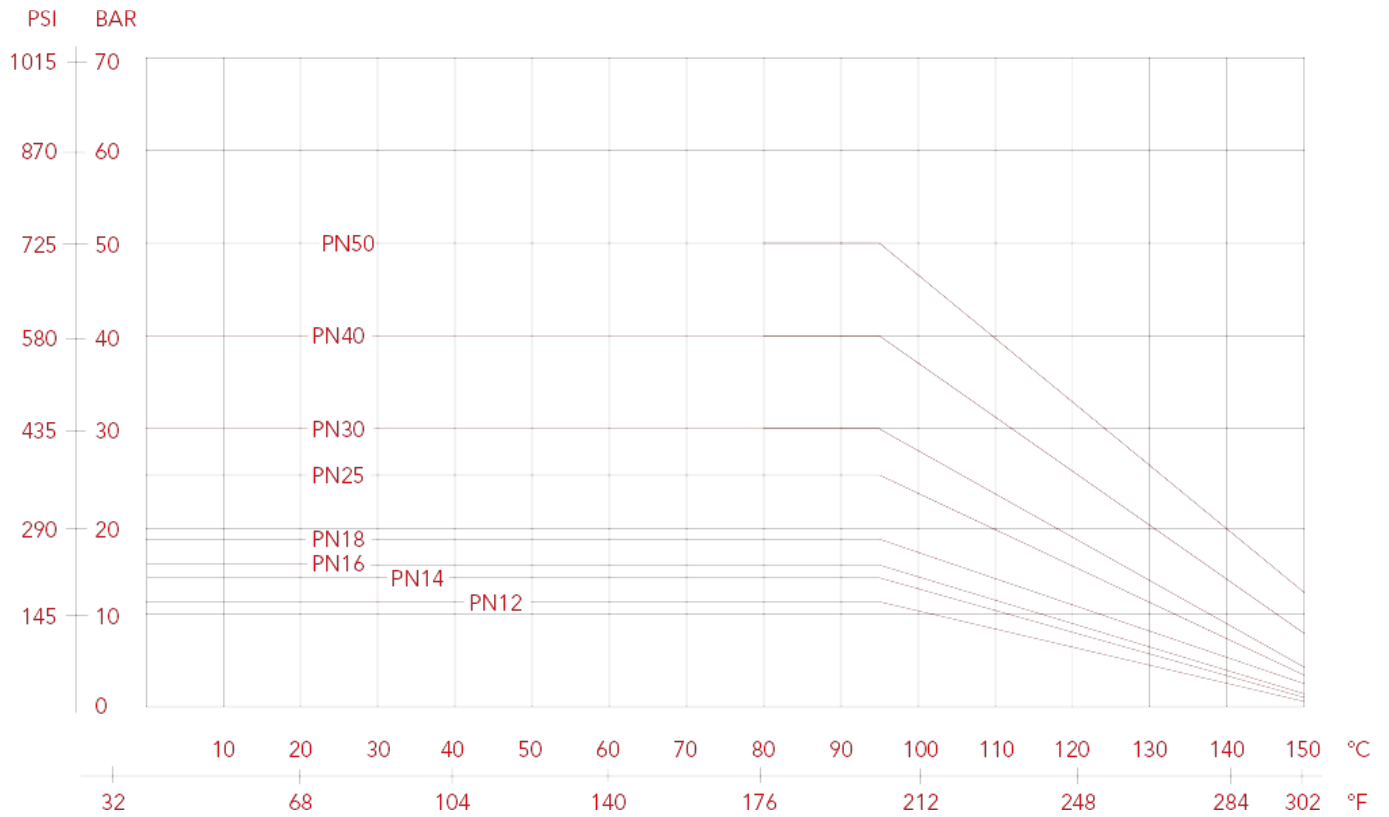



FULL FLOW BALL VALVES: IDEAL

098 Ideal ball valve, full flow for manifolds

Suitable for domestic water services, heating and air-conditioning plants, compressed air systems.

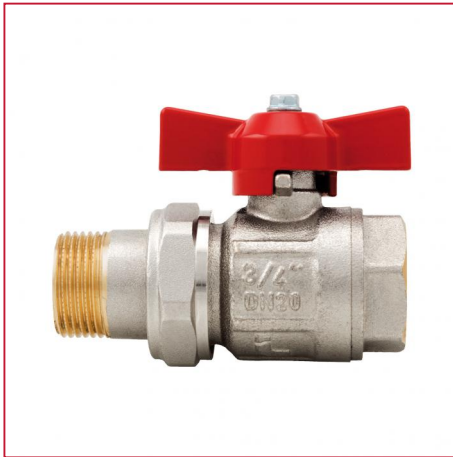

SIZE	PRESSURE	CODE	PACKING
1/2" (DN 15)	50bar/725psi	0980012	8/88
3/4" (DN 20)	40bar/580psi	0980034	6/60
1" (DN 25)	40bar/580psi	0980100	6/48
1"1/4 (DN 32)	30bar/435psi	0980114	4/32
1"1/2 (DN 40)	30bar/435psi	0980112	2/16
2" (DN 50)	25bar/362.5psi	0980200	2/14

CERTIFICATIONS



TECHNICAL SPECIFICATIONS

Male/female threads.

T handle in aluminium.

Body in nickel-plated brass.

Minimum and maximum working temperatures: -20°C, 150°C in absence of steam.

Threads: ISO 228 (equivalent to DIN EN ISO 228 and BS EN ISO 228).

1"1/2 and 2" size with flat seat and lever handle in steel.

OVERALL DIMENSIONS

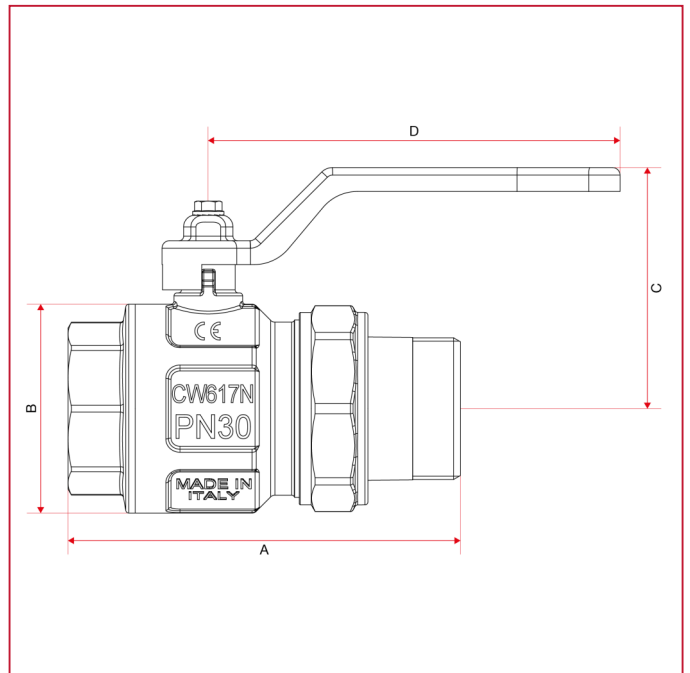
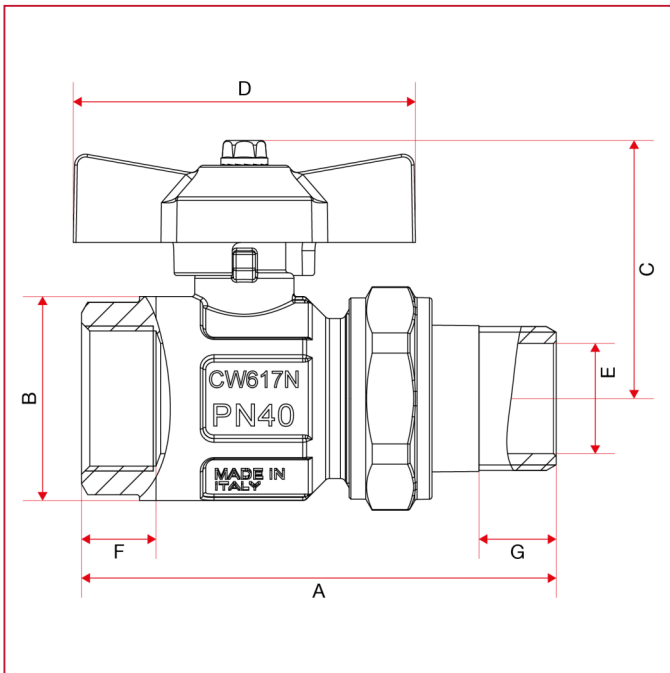



FULL FLOW BALL VALVES: IDEAL

	1/2"	3/4"	1"	1"1/4	1"1/2	2"
DN	15	20	25	32	40	50
A	74	86	99	115	131,5	150,5
B	30,5	37	45,5	57	70	84
C	41	47	50,8	63,5	81	96
D	47	62	62	70	138	157,8
E	15	20	25	32	39	50
F	12,5	13,5	15	16,5	17,5	20,5
G	12	14	16	17	16	17
Kg/cm ² bar	50	40	40	30	30	25
LBS - psi	725	580	580	435	435	362,5

MATERIALS sizes 1/2" through 1"1/4

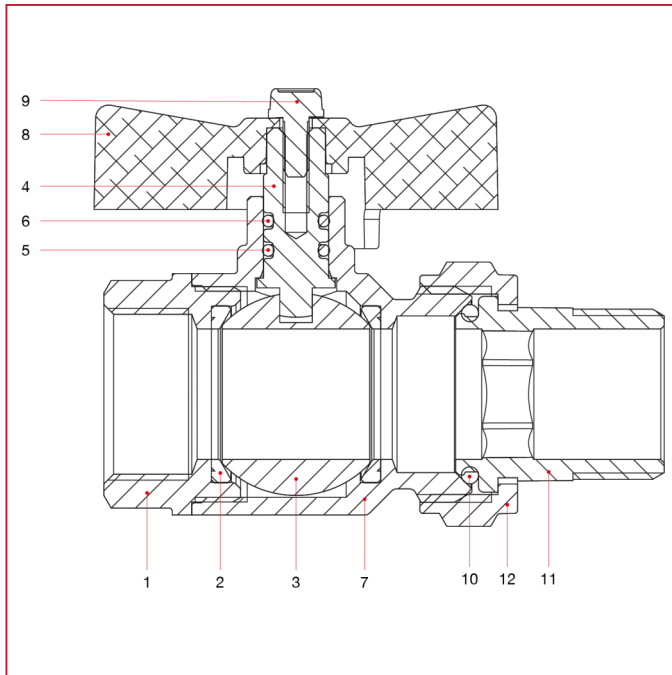

POS.	DESCRIPTION	N.	MATERIAL
1	Female end adapter	1	Nickel-plated brass CW617N
2	Seat	2	P.T.F.E.
3	Ball	1	Chrome-plated brass CW617N
4	Stem	1	Brass CW614N
5	O-ring	1	NBR
6	O-ring	1	Viton®
7	Body	1	Nickel-plated brass CW617N
8	T handle	1	Varnished aluminium
9	Screw	1	Zinc-plated steel C4C
10	O-ring	1	NBR
11	Union	1	Nickel-plated brass CW617N
12	Nut	1	Nickel-plated brass CW617N



FULL FLOW BALL VALVES: IDEAL

MATERIALS sizes 1"1/2 through 2"

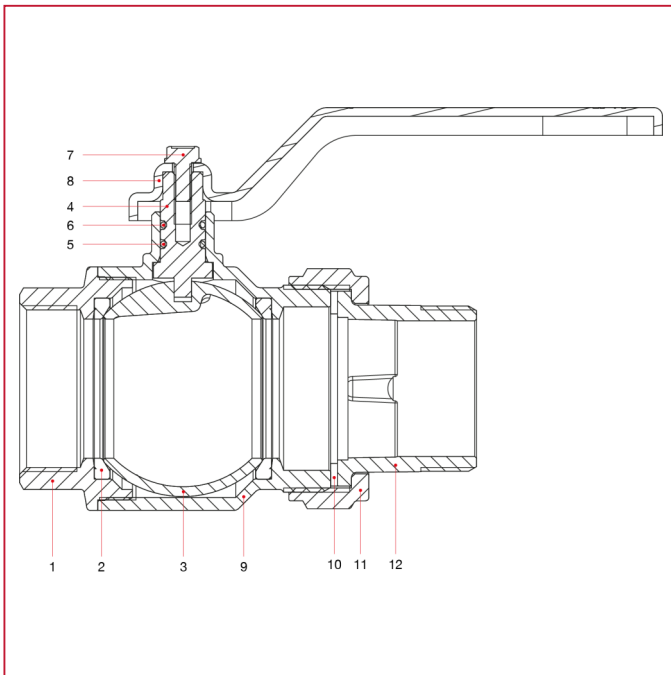

POS.	DESCRIPTION	N.	MATERIAL
1	Female end adapter	1	Nickel-plated brass CW617N
2	Seat	2	P.T.F.E.
3	Ball	1	Chrome-plated brass CW617N
4	Stem	1	Brass CW614N
5	O-ring	1	NBR
6	O-ring	1	Viton®
7	Screw	1	Zinc-plated steel C4C
8	Lever handle	1	Varnished steel P04
9	Body	1	Nickel-plated brass CW617N
10	Flat seat washer	1	NBR
11	Nut	1	Nickel-plated brass CW617N
12	Union	1	Nickel-plated brass CW617N



FULL FLOW BALL VALVES: IDEAL

INSTALLATION

The Itap S.p.A.'s valves are bi-directional, that means they manage the flow in both the directions.

The valves are composed by a ball, two seal in PTFE material, one stem, two sailing rings (O-Rings), one handle and a couple of parts made of brass (body and end adapter) that contain them and that are assembled by means of thread and a sealed material to obtain their aim.

In order to avoid that the sealed material gets broken and then the valve loses the connection between the body and the end-adaptor, it's necessary to avoid to submit the two parts under the influence of a torque.

For the installation normal hydraulic practices must be used, and especially:

- ones have to be sure that the two pipes are correctly aligned;
- during the assembling process the installer has to apply its assembling tools at the end that is nearest to the pipe;
- the application of the sealing materials by the fitter (PTFE or hempen cloth) must be limited at the thread zone. An excess should interfere in the ball-gasket's closure zone, compromising the tightness.
- in the case that the fluid transported presents some impurities (dust, water too hard, etc.) ones have to remove these impurities by the means of a filter. Otherwise they could damage the seals.

DISASSEMBLY

To remove the valve from the pipe line or anyhow before to unscrew the junctions linked to it:

- wear the clothing protective normally required to work with the fluid transported within the line;
- depressurize the line and operate in this way:
 - positioning the valve in opened position and then empty the line;
 - handle the valve to put down the residue pressure contained inside the space between the ball and the body before of remove it from the line;
- during the disassembly apply the screw tool at the end of the valve nearest the pipe;

MAINTENANCE

Verify the valve periodically, according to its application's field and its works' field and its work's conditions, in order to be sure that the valve works correctly.



FULL FLOW BALL VALVES: IDEAL

LOSS DIAGRAM (With water)

	1/2"	3/4"	1"	1"1/4"	1"1/2"	2"
KV	15,65	26,26	41,44	63,69	101	169

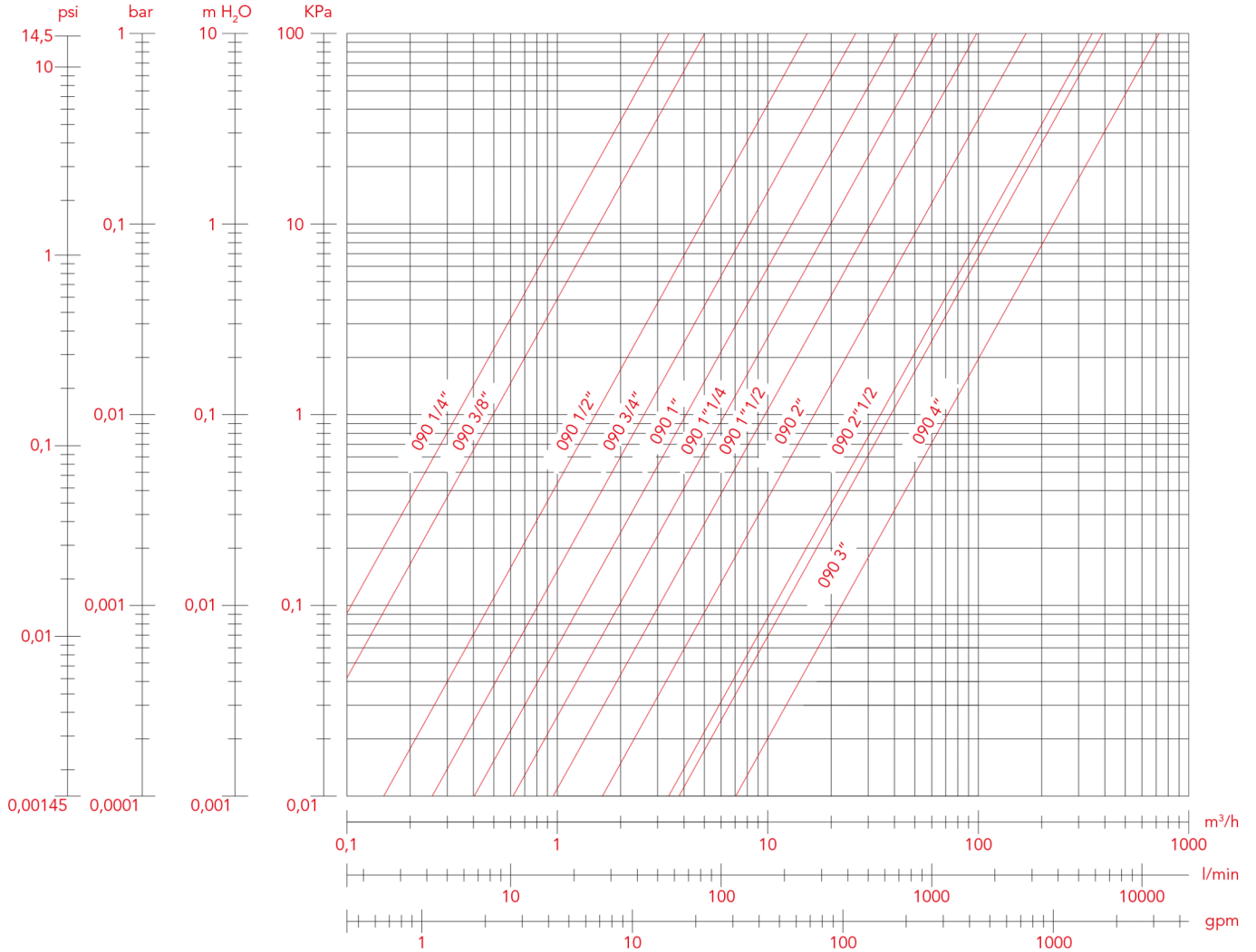



FULL FLOW BALL VALVES: IDEAL

PRESSURE-TEMPERATURE DIAGRAM

The values shown by the dropping lines state the maximum limit of employment of the valves.
The shown values are approximate.

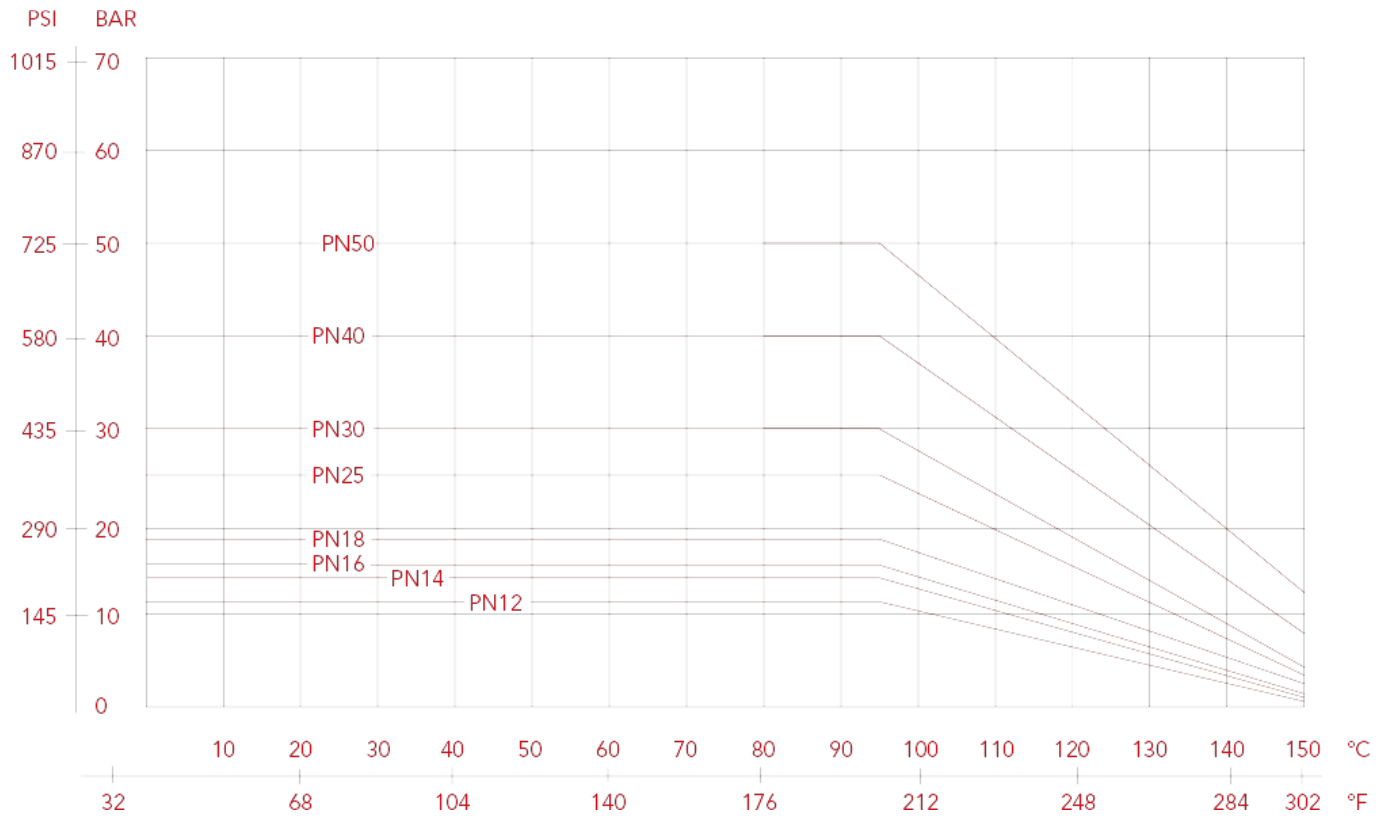



FULL FLOW BALL VALVES: IDEAL

098S Ideal ball valve with o-ring, full flow for manifolds

Suitable for domestic water services, heating and air-conditioning plants, compressed air systems.



SIZE	PRESSURE	CODE	PACKING
1/2" (DN 15)	50bar/725psi	0980012S	8/88
3/4" (DN 20)	40bar/580psi	0980034S/SB	6/48
3/4"X1" (DN 20)	40bar/580psi	0980034100S/SB	6/48
1" (DN 25)	40bar/580psi	0980100S/SB	6/48
1"1/4 (DN 32)	30bar/435psi	0980114S	4/32

CERTIFICATIONS

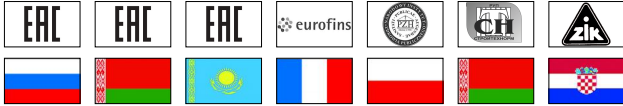

TECHNICAL SPECIFICATIONS

Male/female threads.

T handle in aluminium.

Body in nickel-plated brass.

Minimum and maximum working temperatures: -20°C, 150°C in absence of steam.

Threads: ISO 228 (equivalent to DIN EN ISO 228 and BS EN ISO 228).

3/4" and 1" available also with blue handle.

Mention "SB" in the code only to order the blue handle.

Code 0980034100S: 3/4"Fx1"M



FULL FLOW BALL VALVES: IDEAL

OVERALL DIMENSIONS

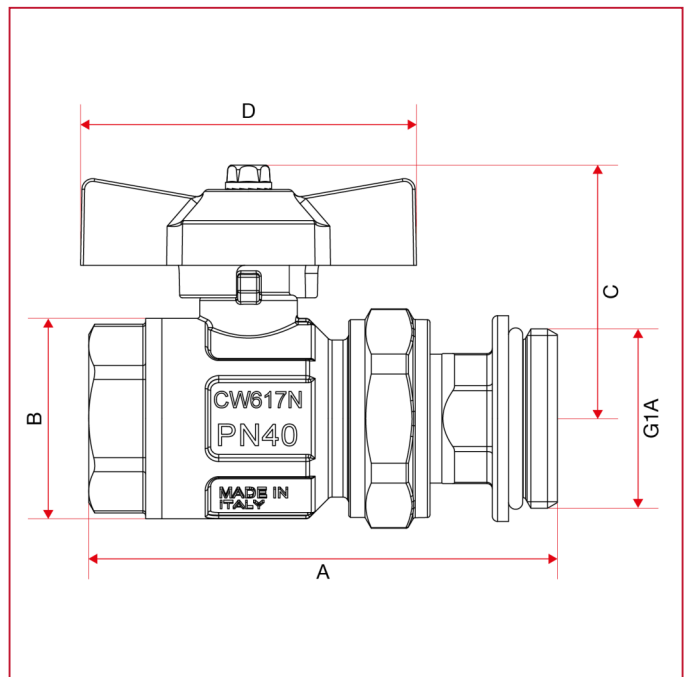
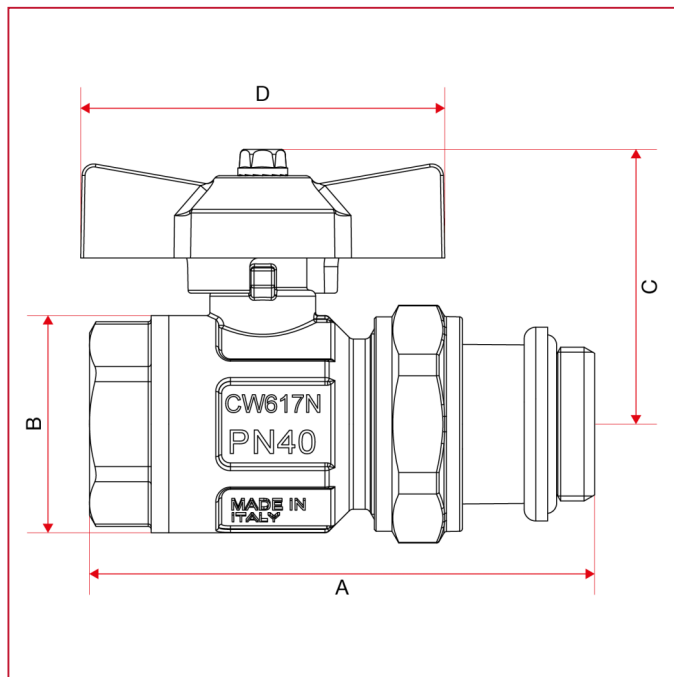

	1/2"	3/4"	3/4"X1"	1"	1"1/4
DN	15	20	20	25	32
A	74	86	86,5	98	113
B	30,5	37	37	45,5	57
C	41	47	47	50,8	63,5
D	47	62	62	62	70
Kg/cm2 bar	50	40	40	40	30
LBS - psi	725	580	580	580	435



FULL FLOW BALL VALVES: IDEAL

MATERIALS

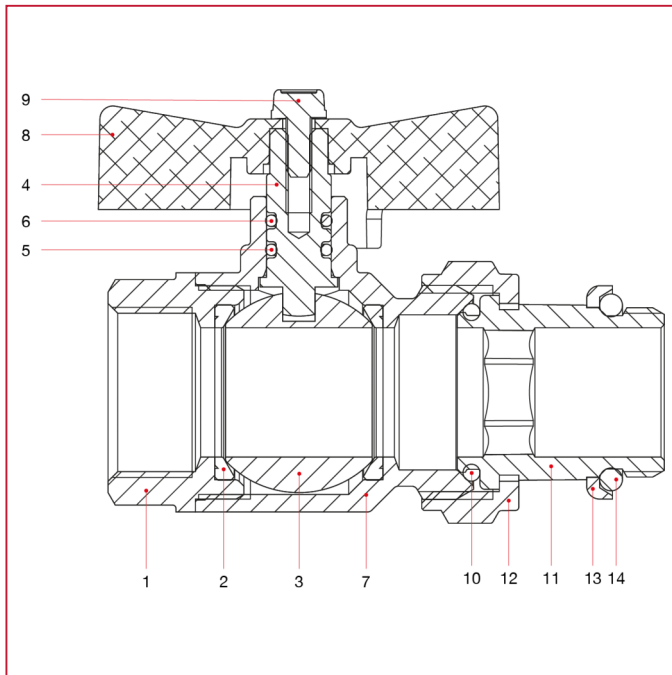

POS.	DESCRIPTION	N.	MATERIAL
1	Female end adapter	1	Nickel-plated brass CW617N
2	Seat	2	P.T.F.E.
3	Ball	1	Chrome-plated brass CW617N
4	Stem	1	Brass CW614N
5	O-ring	1	NBR
6	O-ring	1	Viton®
7	Body	1	Nickel-plated brass CW617N
8	T handle	1	Varnished aluminium
9	Screw	1	Zinc-plated steel C4C
10	O-ring	1	NBR
11	Union	1	Nickel-plated brass CW617N
12	Ring	1	Steel
13	O-ring	1	NBR
14	Nut	1	Nickel-plated brass CW617N



FULL FLOW BALL VALVES: IDEAL

MATERIALS 3/4"x1"

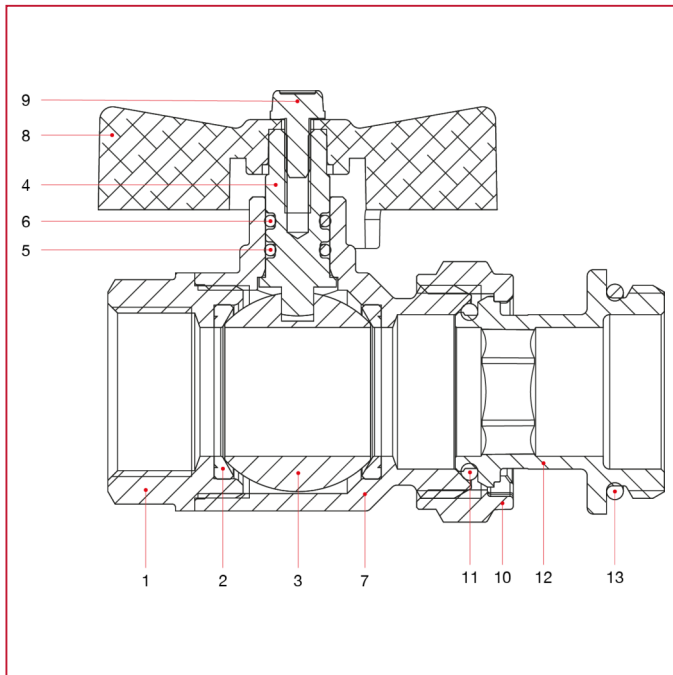

POS.	DESCRIPTION	N.	MATERIAL
1	Female end adapter	1	Nickel-plated brass CW617N
2	Seat	2	P.T.F.E.
3	Ball	1	Chrome-plated brass CW617N
4	Stem	1	Brass CW614N
5	O-ring	1	NBR
6	O-ring	1	Viton®
7	Body	1	Nickel-plated brass CW617N
8	T handle	1	Varnished aluminium
9	Screw	1	Zinc-plated steel C4C
10	Nut	1	Nickel-plated brass CW617N
11	O-ring	1	NBR
12	Union	1	Nickel-plated brass CW617N
13	O-ring	1	EPDM



FULL FLOW BALL VALVES: IDEAL

INSTALLATION

The Itap S.p.A.'s valves are bi-directional, that means they manage the flow in both the directions.

The valves are composed by a ball, two seal in PTFE material, one stem, two sailing rings (O-Rings), one handle and a couple of parts made of brass (body and end adapter) that contain them and that are assembled by means of thread and a sealed material to obtain their aim.

In order to avoid that the sealed material gets broken and then the valve loses the connection between the body and the end-adaptor, it's necessary to avoid to submit the two parts under the influence of a torque.

For the installation normal hydraulic practices must be used, and especially:

- ones have to be sure that the two pipes are correctly aligned;
- during the assembling process the installer has to apply its assembling tools at the end that is nearest to the pipe;
- the application of the sealing materials by the fitter (PTFE or hempen cloth) must be limited at the thread zone. An excess should interfere in the ball-gasket's closure zone, compromising the tightness.
- in the case that the fluid transported presents some impurities (dust, water too hard, etc.) ones have to remove these impurities by the means of a filter. Otherwise they could damage the seals.

DISASSEMBLY

To remove the valve from the pipe line or anyhow before to unscrew the junctions linked to it:

- wear the clothing protective normally required to work with the fluid transported within the line;
- depressurize the line and operate in this way:
 - positioning the valve in opened position and then empty the line;
 - handle the valve to put down the residue pressure contained inside the space between the ball and the body before of remove it from the line;
- during the disassembly apply the screw tool at the end of the valve nearest the pipe;

MAINTENANCE

Verify the valve periodically, according to its application's field and its works' field and its work's conditions, in order to be sure that the valve works correctly.



FULL FLOW BALL VALVES: IDEAL

LOSS DIAGRAM (With water)

	1/2"	3/4"	3/4"X1"	1"	1"1/4"
KV	15,65	26,26	26,26	41,44	63,69

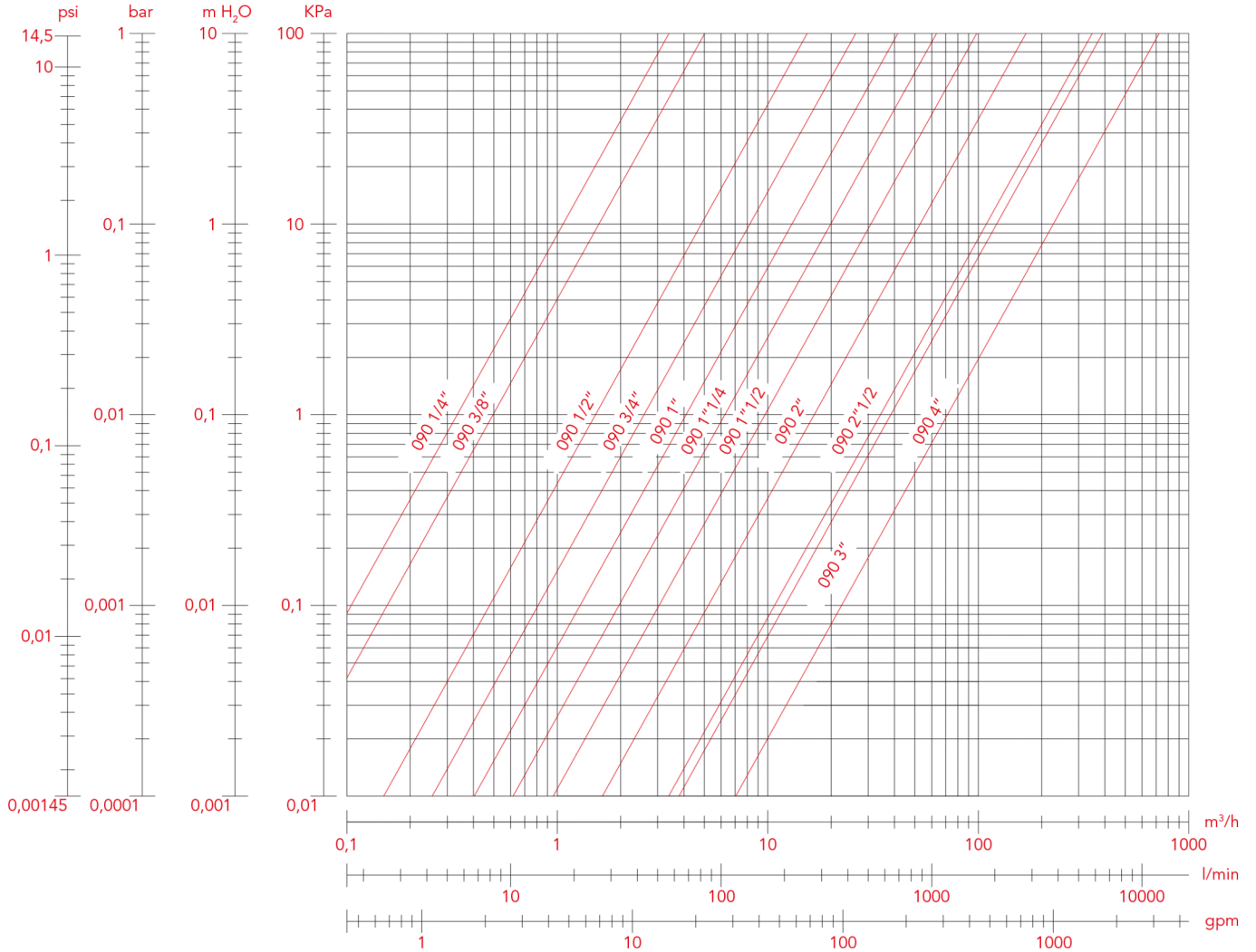



FULL FLOW BALL VALVES: IDEAL

PRESSURE-TEMPERATURE DIAGRAM

The values shown by the dropping lines state the maximum limit of employment of the valves.
The shown values are approximate.

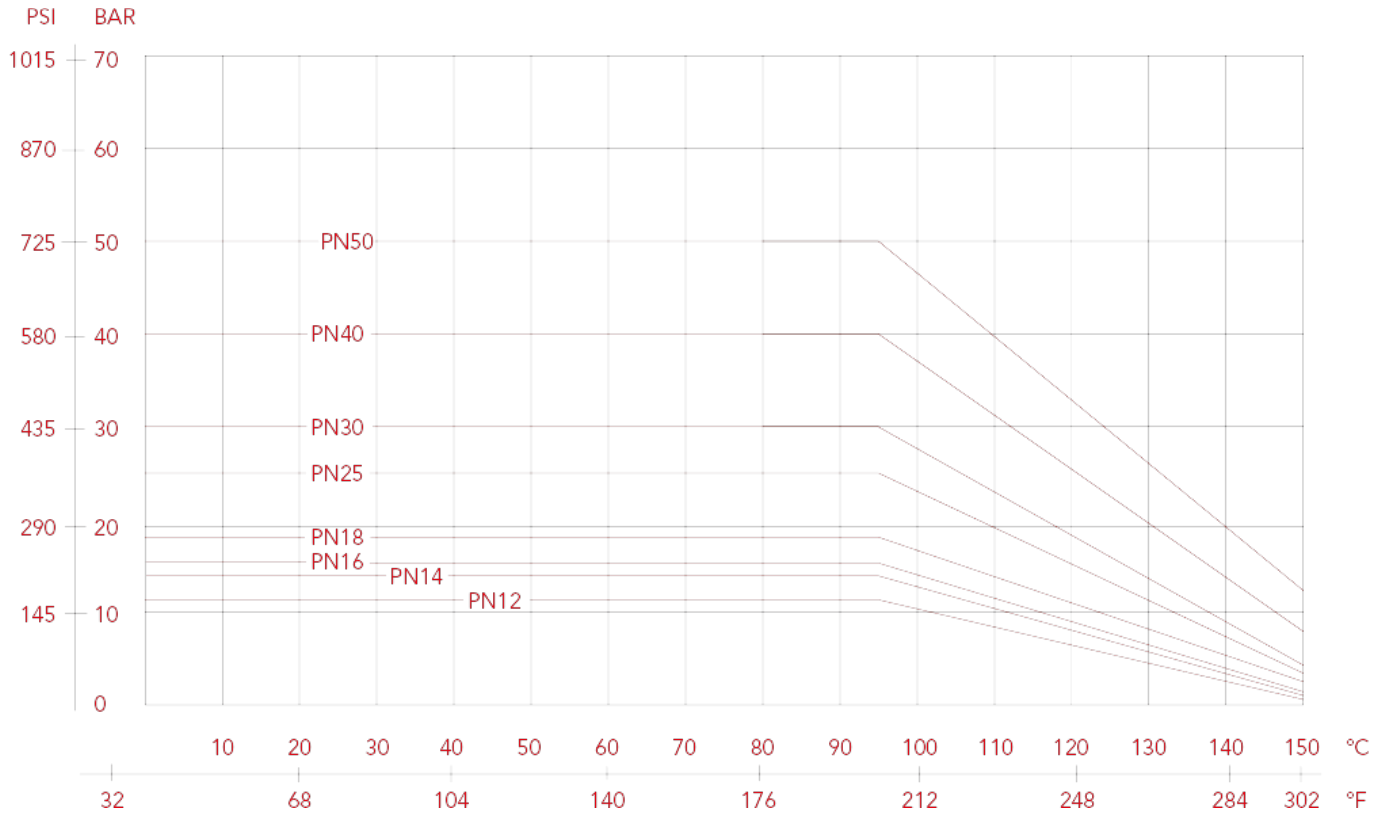



FULL FLOW BALL VALVES: IDEAL

098SDC Ideal ball valve without union, full flow for manifolds

Suitable for domestic water services, heating and air-conditioning plants, compressed air systems.

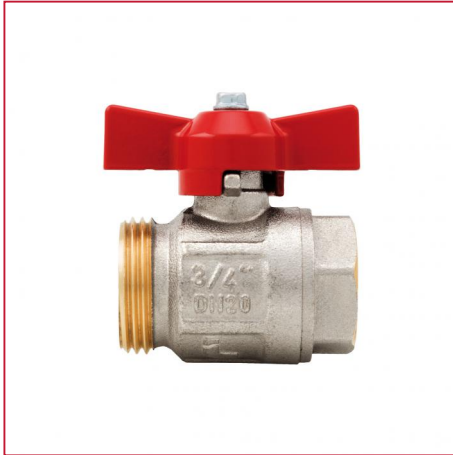

SIZE	PRESSURE	CODE	PACKING
3/4" (DN 20)	40bar/580psi	0980034SDC/B	8/88
1" (DN 25)	40bar/580psi	0980100SDC/B	8/64
1"1/4 (DN 32)	30bar/435psi	0980114SDC/B	4/40

CERTIFICATIONS

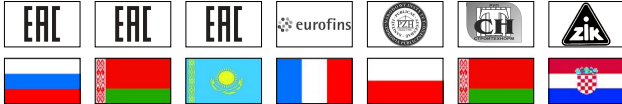

TECHNICAL SPECIFICATIONS

Male/female threads.

T handle in aluminium.

Body in nickel-plated brass.

Minimum and maximum working temperatures: -20°C, 150°C in absence of steam.

Threads: ISO 228 (equivalent to DIN EN ISO 228 and BS EN ISO 228).

Male thread with conical seat.

Available sizes: 3/4" F X 1" M, 1" F X 1" 1/4 M, 1" 1/4 F X 1" 1/2 M.

Mention "B" in the code to order the blue T handle.



FULL FLOW BALL VALVES: IDEAL

OVERALL DIMENSIONS

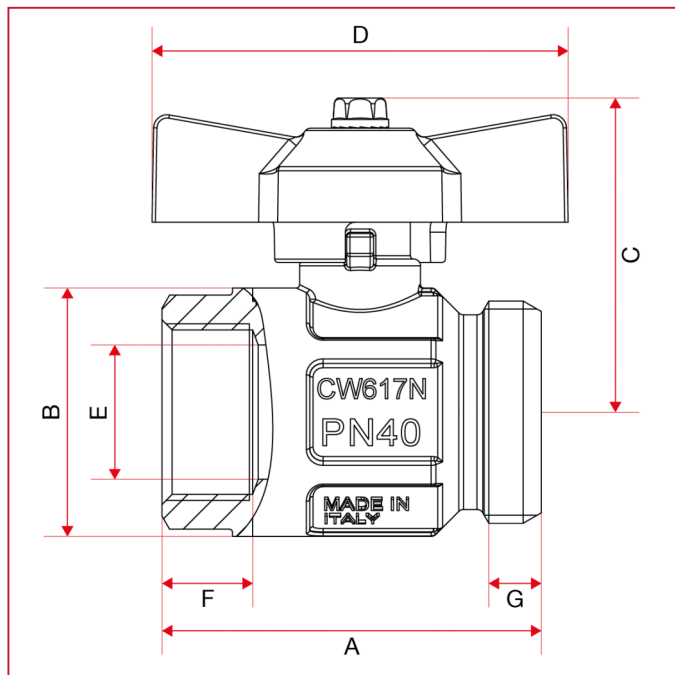

	3/4"	1"	1"1/4
DN	20	25	32
A	56,5	64,75	76
B	37	45,5	57
C	47	50,8	64
D	62	62	70
E	20	25	32
F	13,5	15	16,5
G	8	10,5	14
Kg/cm ² bar	40	40	30
LBS - psi	580	580	435



FULL FLOW BALL VALVES: IDEAL

MATERIALS

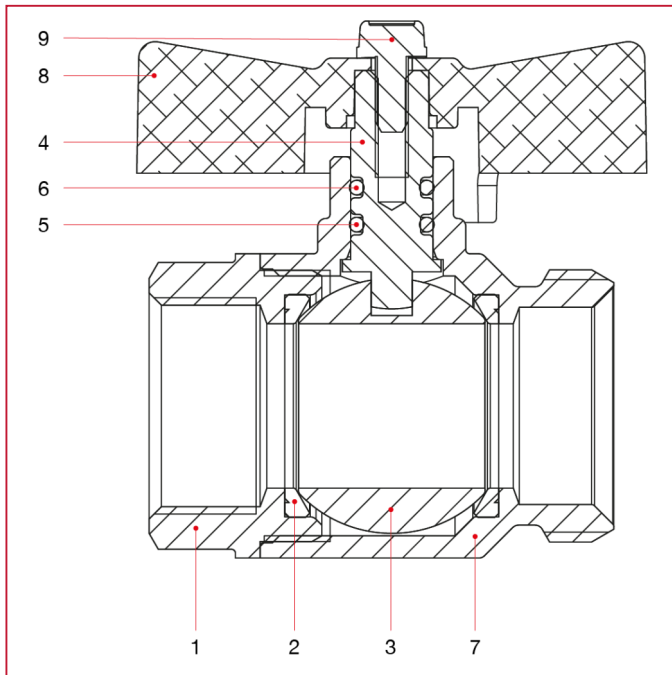

POS.	DESCRIPTION	N.	MATERIAL
1	Female end adapter	1	Nickel-plated brass CW617N
2	Seat	2	P.T.F.E.
3	Ball	1	Chrome-plated brass CW617N
4	Body	1	Nickel-plated brass CW617N
5	Stem	1	Brass CW614N
6	O-ring	1	NBR
7	O-ring	1	Viton®
8	T handle	1	Varnished aluminium
9	Screw	1	Zinc-plated steel C4C



FULL FLOW BALL VALVES: IDEAL

INSTALLATION

The Itap S.p.A.'s valves are bi-directional, that means they manage the flow in both the directions.

The valves are composed by a ball, two seal in PTFE material, one stem, two sailing rings (O-Rings), one handle and a couple of parts made of brass (body and end adapter) that contain them and that are assembled by means of thread and a sealed material to obtain their aim.

In order to avoid that the sealed material gets broken and then the valve loses the connection between the body and the end-adaptor, it's necessary to avoid to submit the two parts under the influence of a torque.

For the installation normal hydraulic practices must be used, and especially:

- ones have to be sure that the two pipes are correctly aligned;
- during the assembling process the installer has to apply its assembling tools at the end that is nearest to the pipe;
- the application of the sealing materials by the fitter (PTFE or hempen cloth) must be limited at the thread zone. An excess should interfere in the ball-gasket's closure zone, compromising the tightness.
- in the case that the fluid transported presents some impurities (dust, water too hard, etc.) ones have to remove these impurities by the means of a filter. Otherwise they could damage the seals.

DISASSEMBLY

To remove the valve from the pipe line or anyhow before to unscrew the junctions linked to it:

- wear the clothing protective normally required to work with the fluid transported within the line;
- depressurize the line and operate in this way:
 - positioning the valve in opened position and then empty the line;
 - handle the valve to put down the residue pressure contained inside the space between the ball and the body before of remove it from the line;
- during the disassembly apply the screw tool at the end of the valve nearest the pipe;

MAINTENANCE

Verify the valve periodically, according to its application's field and its works' field and its work's conditions, in order to be sure that the valve works correctly.



FULL FLOW BALL VALVES: IDEAL

LOSS DIAGRAM (With water)

	3/4"	1"	1"1/4"
KV	26,26	41,44	63,69

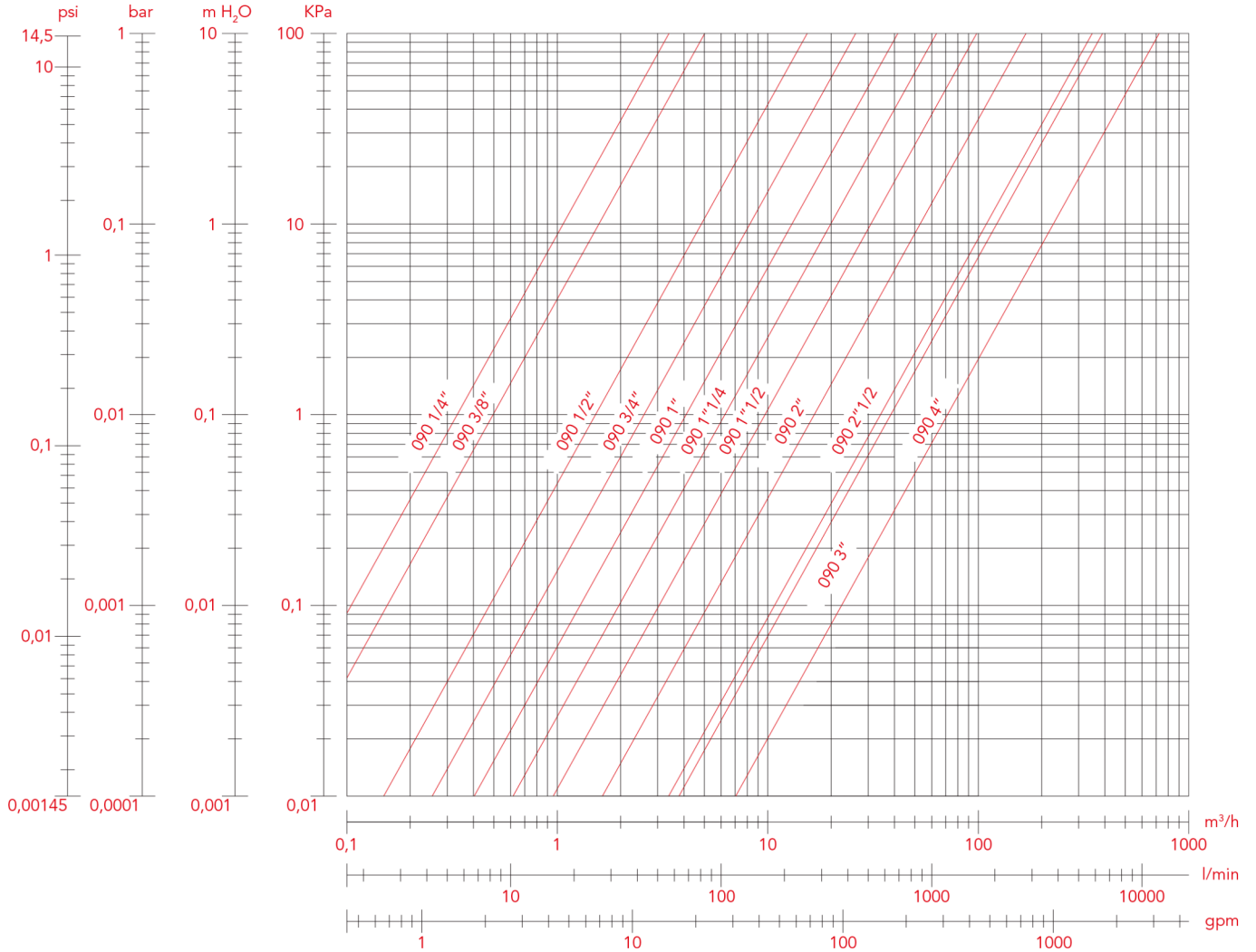



FULL FLOW BALL VALVES: IDEAL

PRESSURE-TEMPERATURE DIAGRAM

The values shown by the dropping lines state the maximum limit of employment of the valves.
The shown values are approximate.

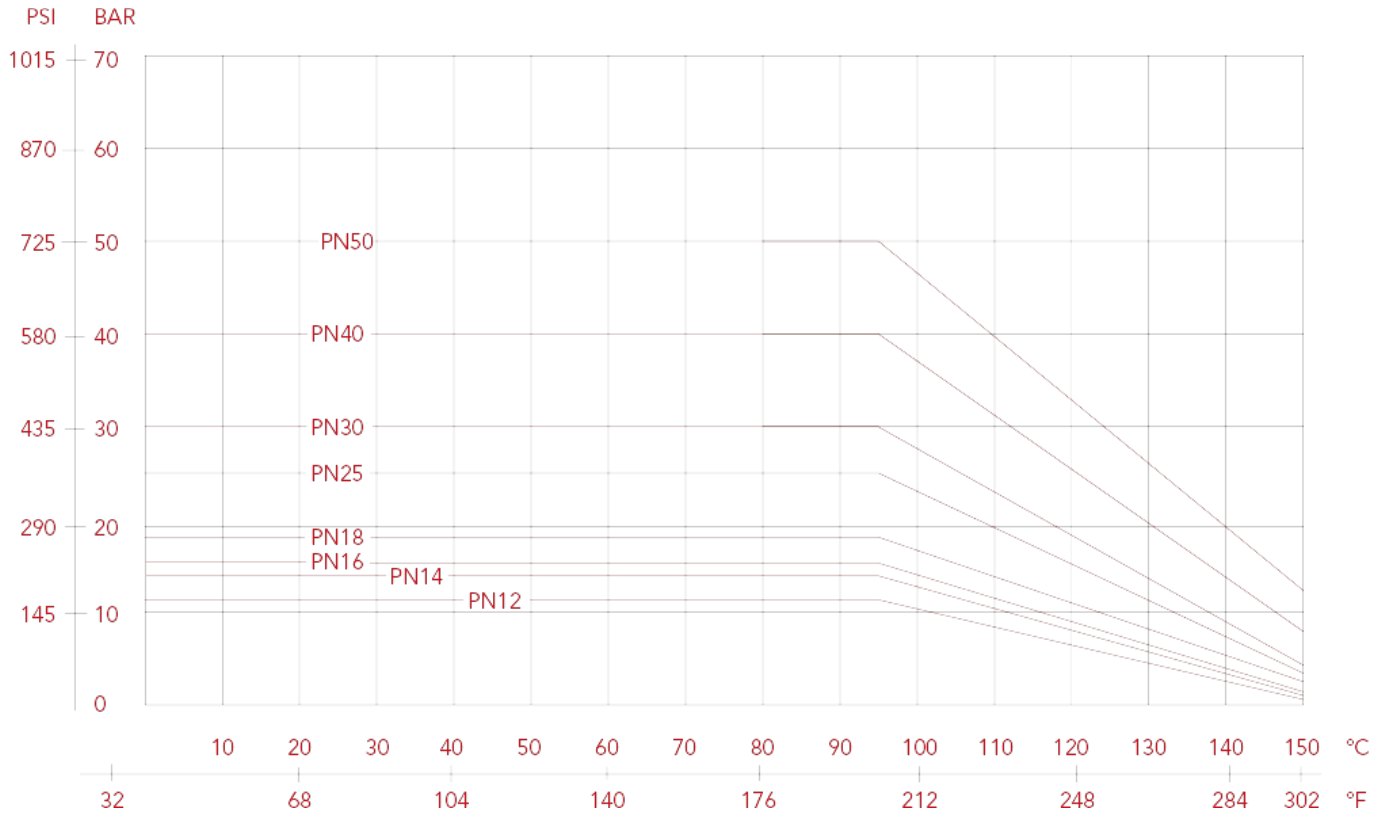



FULL FLOW BALL VALVES: IDEAL

298 Ideal angle ball valve, full flow for manifolds

Suitable for domestic water services, heating and air-conditioning plants, compressed air systems.



SIZE	PRESSURE	CODE	PACKING
1/2" (DN 15)	50bar/725psi	2980012	6/96
3/4" (DN 20)	40bar/580psi	2980034	6/48
1" (DN 25)	40bar/580psi	2980100	4/32

CERTIFICATIONS



TECHNICAL SPECIFICATIONS

Male/female threads.

T handle in aluminium.

Body in nickel-plated brass.

Minimum and maximum working temperatures: -20°C, 150°C in absence of steam.

Threads: ISO 228 (equivalent to DIN EN ISO 228 and BS EN ISO 228).

OVERALL DIMENSIONS

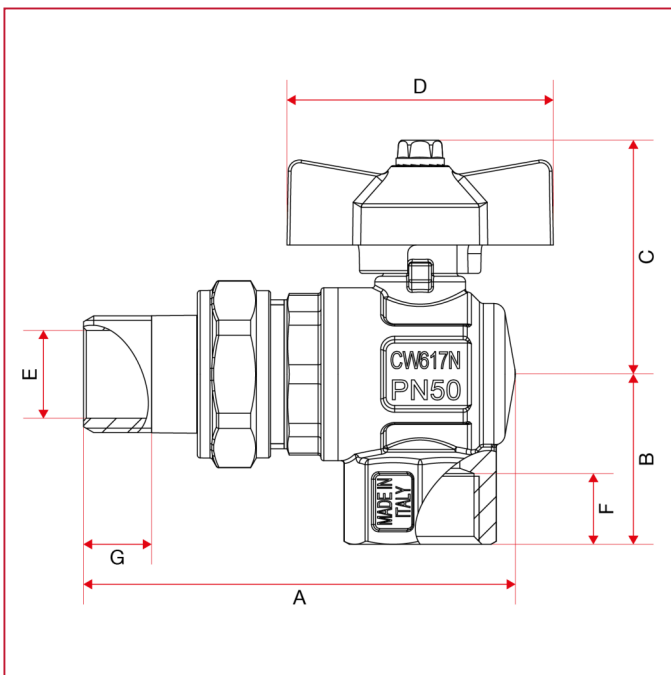



FULL FLOW BALL VALVES: IDEAL

	1/2"	3/4"	1"
DN	15	20	25
A	76,2	89,5	106,5
B	30	33,5	39,75
C	41	47	51
D	47	62	62
E	14	18	23
F	12,5	13,5	15
G	12	14	16
Kg/cm ² bar	50	40	40
LBS - psi	725	580	580

MATERIALS

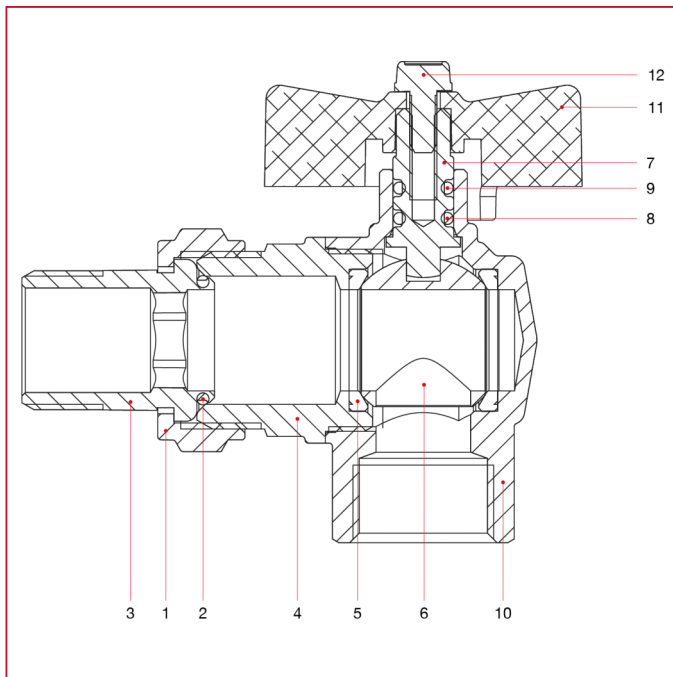

POS.	DESCRIPTION	N.	MATERIAL
1	Nut	1	Nickel-plated brass CW617N
2	O-ring	1	NBR
3	Union	1	Nickel-plated brass CW617N
4	End adapter	1	Nickel-plated brass CW617N
5	Seat	2	P.T.F.E.
6	Ball	1	Chrome-plated brass CW617N
7	Stem	1	Brass CW614N
8	O-ring	1	NBR
9	O-ring	1	Viton®
10	Body	1	Nickel-plated brass CW617N
11	T handle	1	Varnished aluminium
12	Screw	1	Zinc-plated steel C4C



FULL FLOW BALL VALVES: IDEAL

INSTALLATION

The Itap S.p.A.'s valves are bi-directional, that means they manage the flow in both the directions.

The valves are composed by a ball, two seal in PTFE material, one stem, two sailing rings (O-Rings), one handle and a couple of parts made of brass (body and end adapter) that contain them and that are assembled by means of thread and a sealed material to obtain their aim.

In order to avoid that the sealed material gets broken and then the valve loses the connection between the body and the end-adaptor, it's necessary to avoid to submit the two parts under the influence of a torque.

For the installation normal hydraulic practices must be used, and especially:

- ones have to be sure that the two pipes are correctly aligned;
- during the assembling process the installer has to apply its assembling tools at the end that is nearest to the pipe;
- the application of the sealing materials by the fitter (PTFE or hempen cloth) must be limited at the thread zone. An excess should interfere in the ball-gasket's closure zone, compromising the tightness.
- in the case that the fluid transported presents some impurities (dust, water too hard, etc.) ones have to remove these impurities by the means of a filter. Otherwise they could damage the seals.

DISASSEMBLY

To remove the valve from the pipe line or anyhow before to unscrew the junctions linked to it:

- wear the clothing protective normally required to work with the fluid transported within the line;
- depressurize the line and operate in this way:
 - positioning the valve in opened position and then empty the line;
 - handle the valve to put down the residue pressure contained inside the space between the ball and the body before of remove it from the line;
- during the disassembly apply the screw tool at the end of the valve nearest the pipe;

MAINTENANCE

Verify the valve periodically, according to its application's field and its works' field and its work's conditions, in order to be sure that the valve works correctly.



FULL FLOW BALL VALVES: IDEAL

LOSS DIAGRAM (With water)

	1/2"	3/4"	1"
KV	6	12	19,2

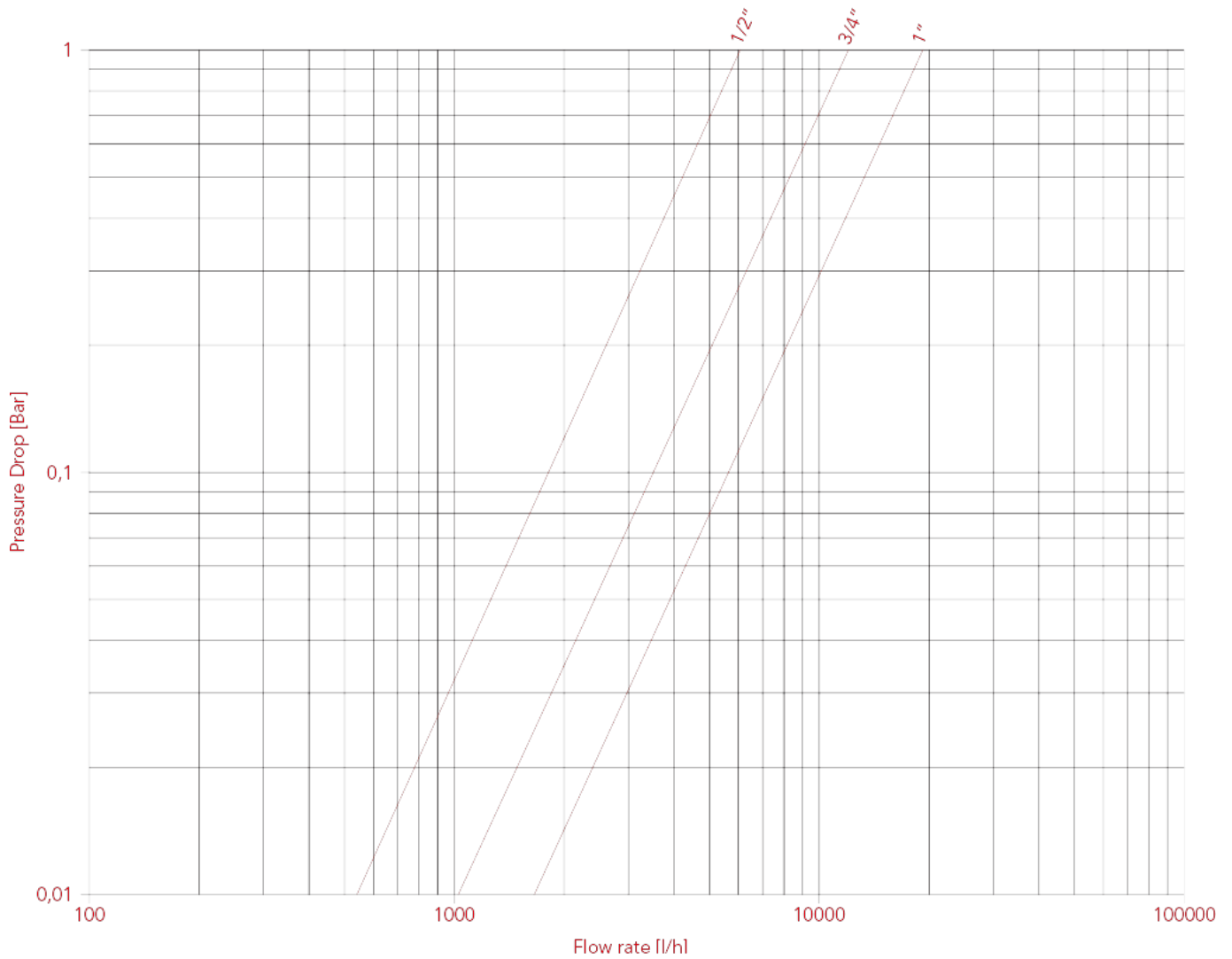



FULL FLOW BALL VALVES: IDEAL

PRESSURE-TEMPERATURE DIAGRAM

The values shown by the dropping lines state the maximum limit of employment of the valves.
The shown values are approximate.

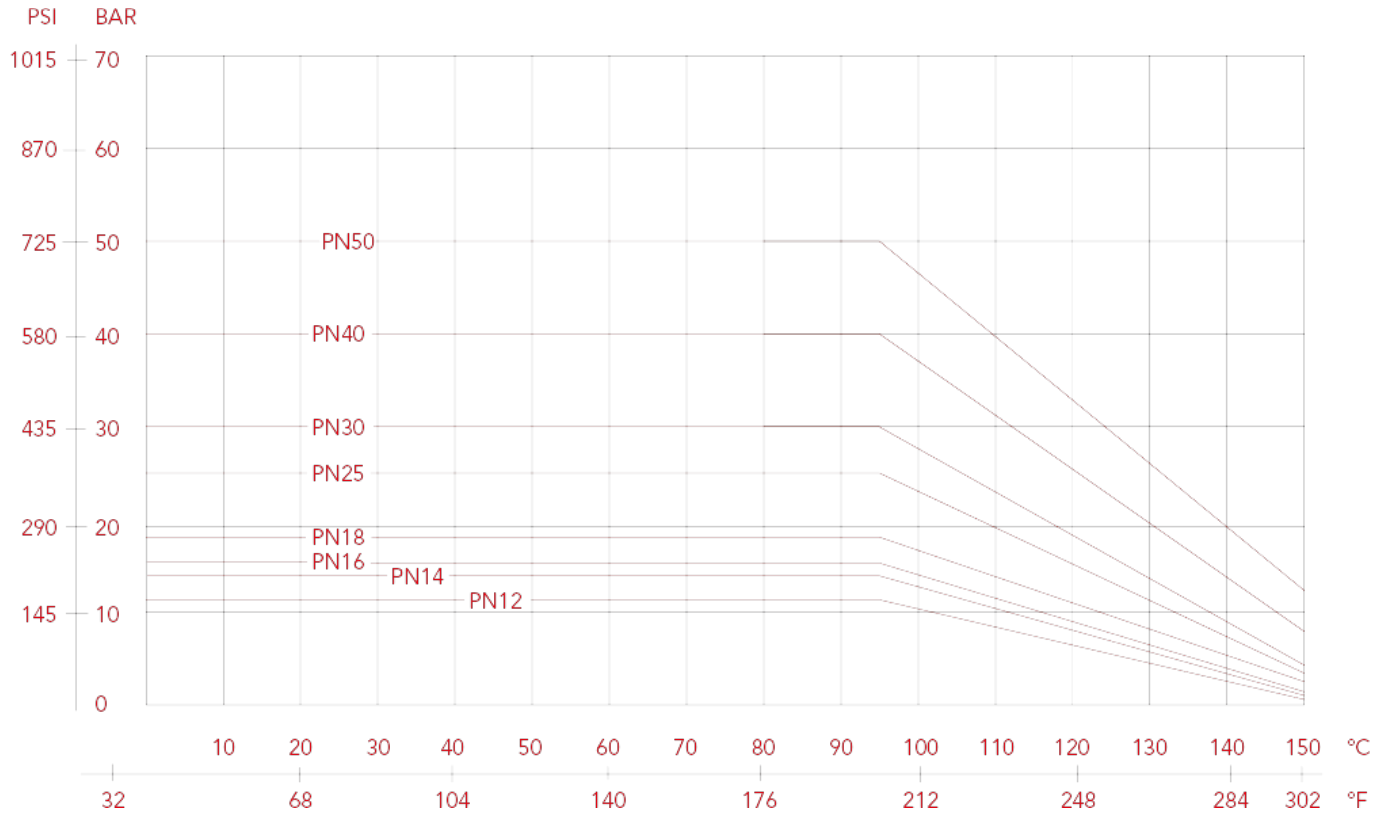



FULL FLOW BALL VALVES: IDEAL

298S Ideal angle ball valve with o-ring, full flow for manifolds

Suitable for domestic water services, heating and air-conditioning plants, compressed air systems.



SIZE	PRESSURE	CODE	PACKING
1/2" (DN 15)	50bar/725psi	2980012S	6/66
3/4" (DN 20)	40bar/580psi	2980034S/SB	6/48
1" (DN 25)	40bar/580psi	2980100S/SB	4/32

CERTIFICATIONS

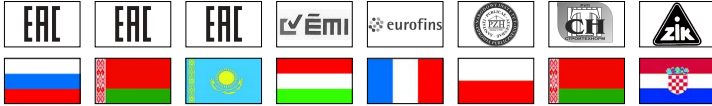

TECHNICAL SPECIFICATIONS

Male/female threads.

T handle in aluminium.

Body in nickel-plated brass.

Minimum and maximum working temperatures: -20°C, 150°C in absence of steam.

Threads: ISO 228 (equivalent to DIN EN ISO 228 and BS EN ISO 228).

3/4" and 1" available also with blue handle.

Mention "SB" in the code only to order the blue handle.



FULL FLOW BALL VALVES: IDEAL

OVERALL DIMENSIONS

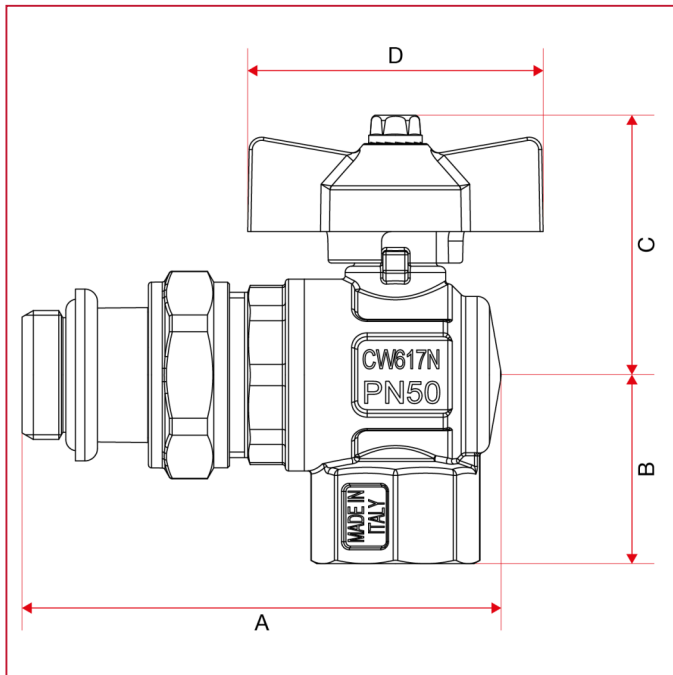

	1/2"	3/4"	1"
DN	15	20	25
A	76,2	89,5	105,5
B	30	33,5	39,75
C	41	47	51
D	47	62	62
Kg/cm ² bar	50	40	40
LBS - psi	725	580	580



FULL FLOW BALL VALVES: IDEAL

MATERIALS

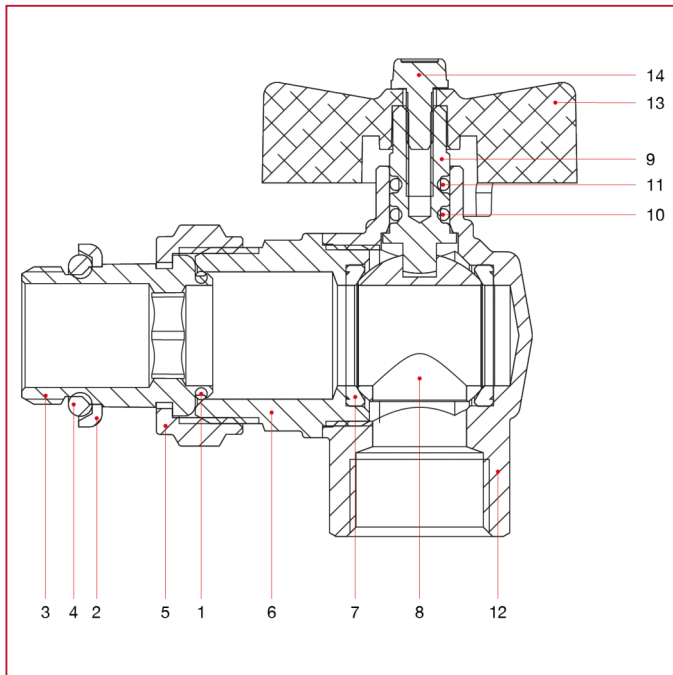

POS.	DESCRIPTION	N.	MATERIAL
1	O-ring	1	NBR
2	Ring	1	Steel
3	Union	1	Nickel-plated brass CW617N
4	O-ring	1	NBR
5	Nut	1	Nickel-plated brass CW617N
6	End adapter	1	Nickel-plated brass CW617N
7	Seat	2	P.T.F.E.
8	Ball	1	Chrome-plated brass CW617N
9	Stem	1	Brass CW614N
10	O-ring	1	NBR
11	O-ring	1	Viton®
12	Body	1	Nickel-plated brass CW617N
13	T handle	1	Varnished aluminium
14	Screw	1	Zinc-plated steel C4C



FULL FLOW BALL VALVES: IDEAL

INSTALLATION

The Itap S.p.A.'s valves are bi-directional, that means they manage the flow in both the directions.

The valves are composed by a ball, two seal in PTFE material, one stem, two sailing rings (O-Rings), one handle and a couple of parts made of brass (body and end adapter) that contain them and that are assembled by means of thread and a sealed material to obtain their aim.

In order to avoid that the sealed material gets broken and then the valve loses the connection between the body and the end-adaptor, it's necessary to avoid to submit the two parts under the influence of a torque.

For the installation normal hydraulic practices must be used, and especially:

- ones have to be sure that the two pipes are correctly aligned;
- during the assembling process the installer has to apply its assembling tools at the end that is nearest to the pipe;
- the application of the sealing materials by the fitter (PTFE or hempen cloth) must be limited at the thread zone. An excess should interfere in the ball-gasket's closure zone, compromising the tightness.
- in the case that the fluid transported presents some impurities (dust, water too hard, etc.) ones have to remove these impurities by the means of a filter. Otherwise they could damage the seals.

DISASSEMBLY

To remove the valve from the pipe line or anyhow before to unscrew the junctions linked to it:

- wear the clothing protective normally required to work with the fluid transported within the line;
- depressurize the line and operate in this way:
 - positioning the valve in opened position and then empty the line;
 - handle the valve to put down the residue pressure contained inside the space between the ball and the body before of remove it from the line;
- during the disassembly apply the screw tool at the end of the valve nearest the pipe;

MAINTENANCE

Verify the valve periodically, according to its application's field and its works' field and its work's conditions, in order to be sure that the valve works correctly.



FULL FLOW BALL VALVES: IDEAL

LOSS DIAGRAM (With water)

	1/2"	3/4"	1"
KV	6	12	19,2

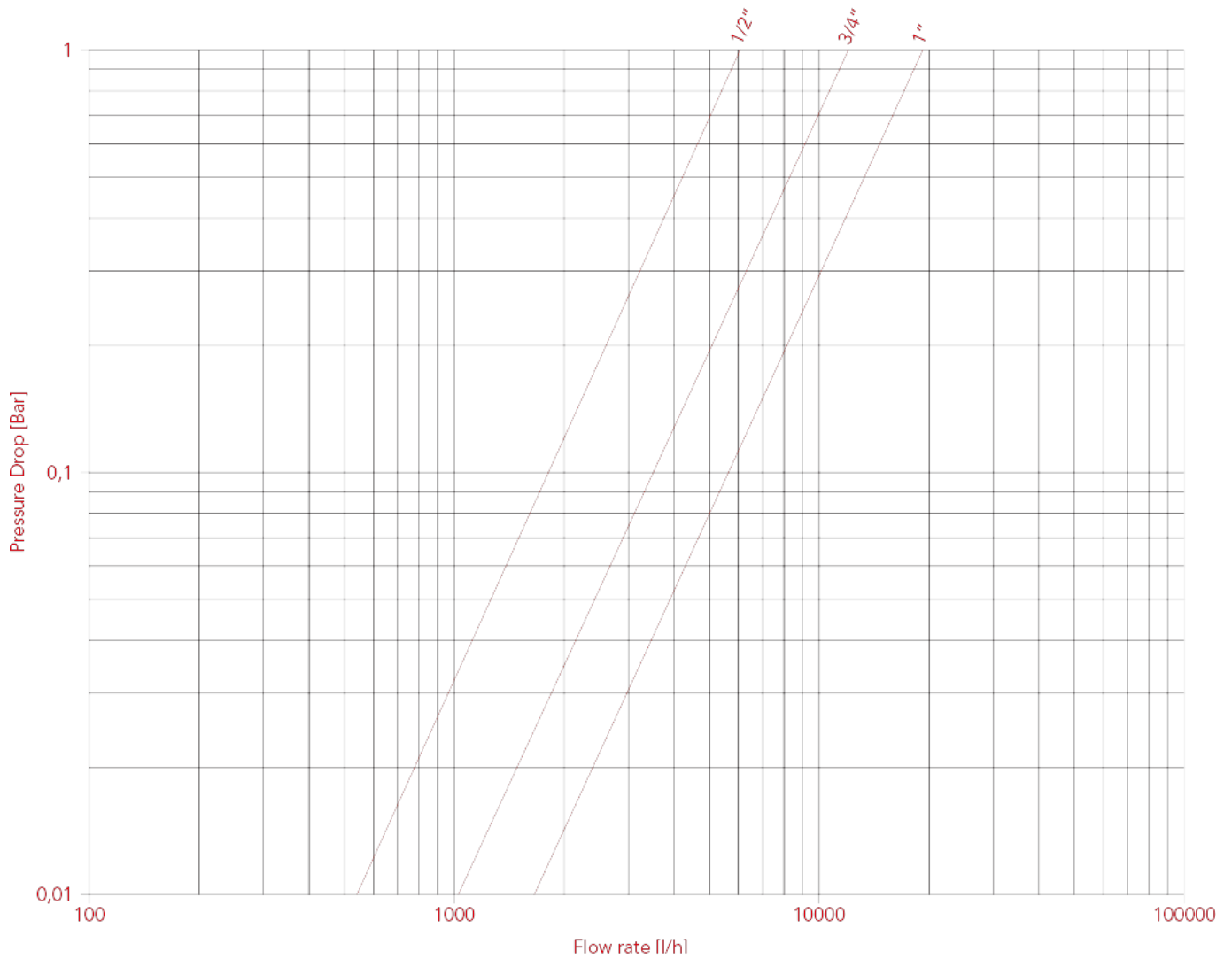



FULL FLOW BALL VALVES: IDEAL

PRESSURE-TEMPERATURE DIAGRAM

The values shown by the dropping lines state the maximum limit of employment of the valves.
The shown values are approximate.

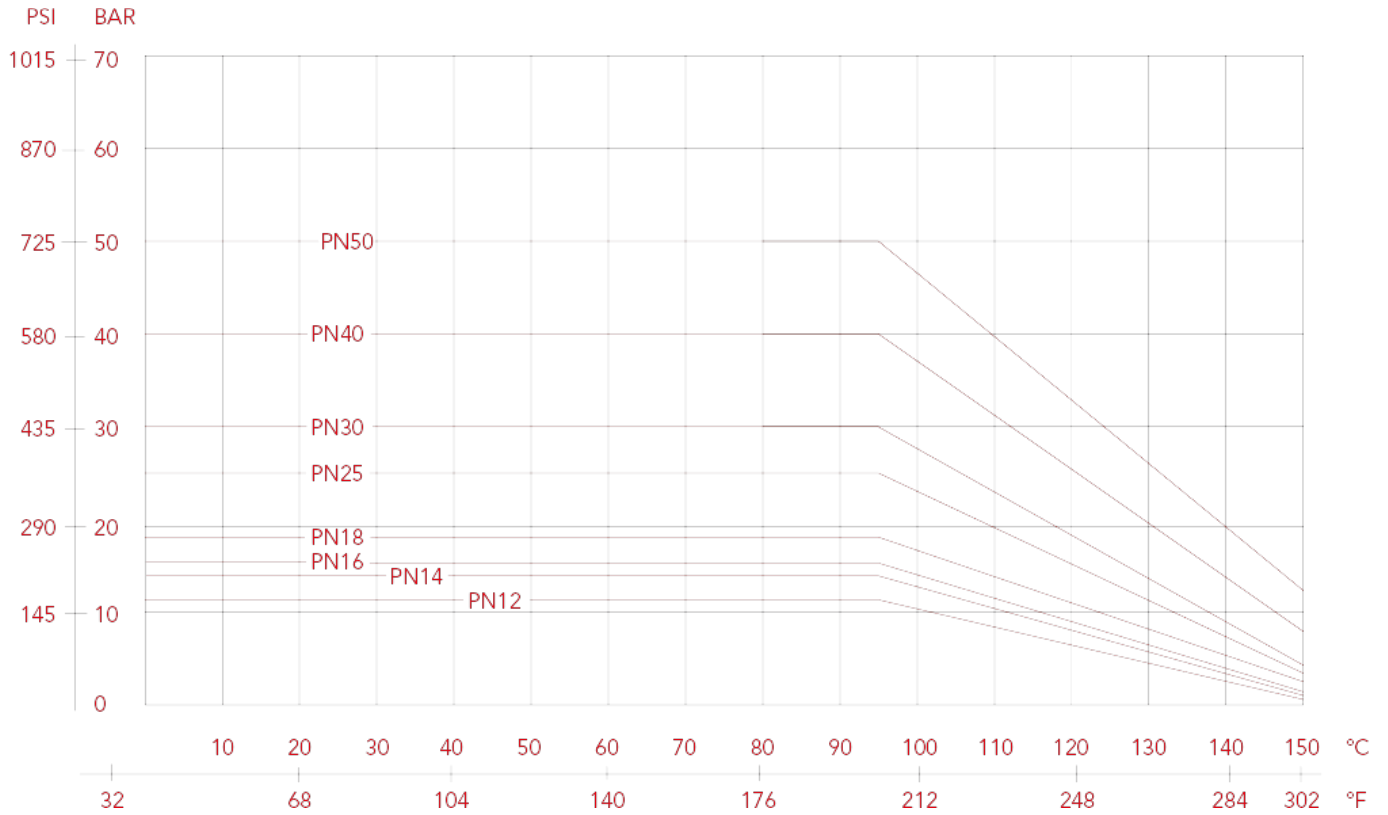



FULL FLOW BALL VALVES: IDEAL

298SDC Ideal angle ball valve without union, full flow for manifolds

Suitable for domestic water services, heating and air-conditioning plants, compressed air systems.



SIZE	PRESSURE	CODE	PACKING
3/4" (DN 20)	40bar/580psi	2980034SDC/B	6/60
1" (DN 25)	40bar/580psi	2980100SDC/B	4/52

CERTIFICATIONS

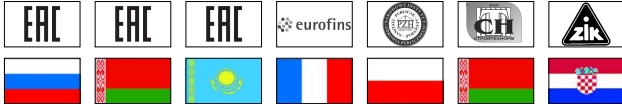

TECHNICAL SPECIFICATIONS

Male/female threads.

T handle in aluminium.

Body in nickel-plated brass.

Minimum and maximum working temperatures: -20°C, 150°C in absence of steam.

Threads: ISO 228 (equivalent to DIN EN ISO 228 and BS EN ISO 228).

Male thread with conical seat.

Available sizes: 3/4" F x 1" M - 1" F x 1 1/4" M

Mention "B" in the code to order the blue T handle.



FULL FLOW BALL VALVES: IDEAL

OVERALL DIMENSIONS

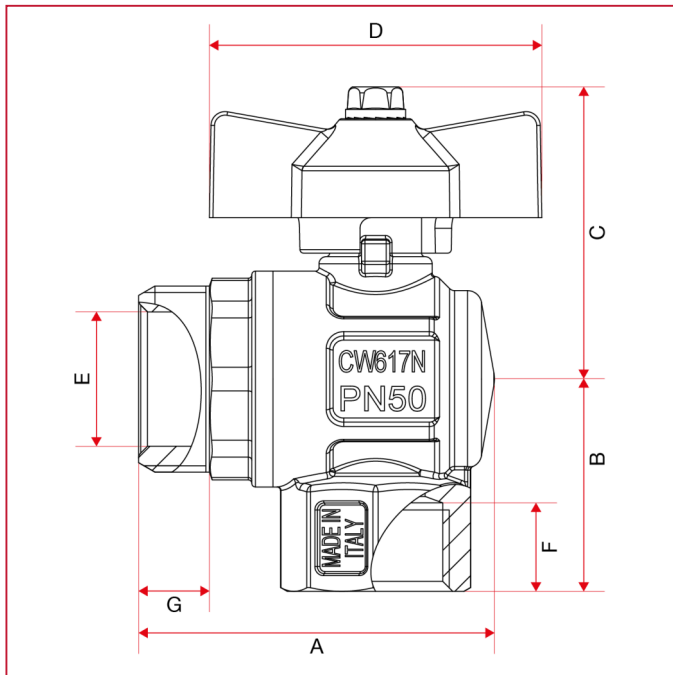

	3/4"	1"
DN	20	25
A	40	47
B	33,5	39,75
C	47	51
D	62	62
E	18	23
F	13,5	15
G	12	14
Kg/cm ² bar	40	40
LBS - psi	580	580



FULL FLOW BALL VALVES: IDEAL

MATERIALS

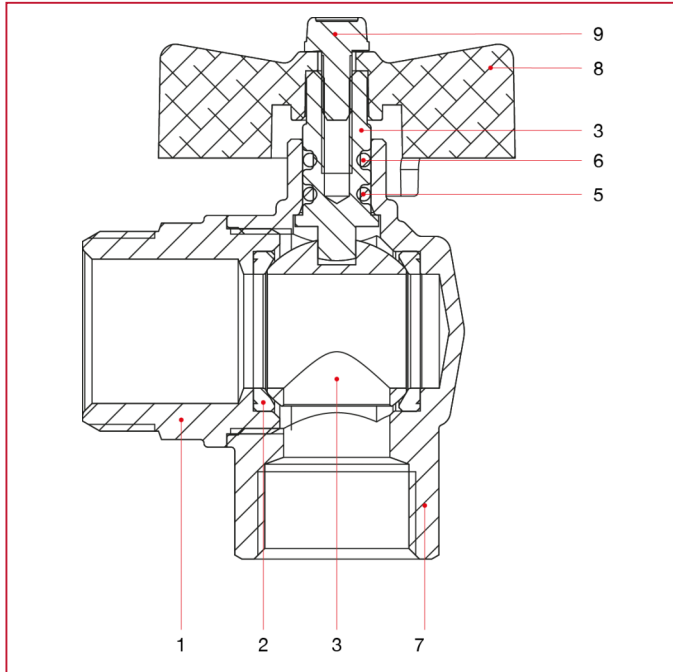

POS.	DESCRIPTION	N.	MATERIAL
1	Male end adapter	1	Nickel-plated brass CW617N
2	Seat	2	P.T.F.E.
3	Ball	1	Chrome-plated brass CW617N
4	Stem	1	Brass CW614N
5	O-ring	1	NBR
6	O-ring	1	Viton®
7	Body	1	Nickel-plated brass CW617N
8	T handle	1	Varnished aluminium
9	Screw	1	Zinc-plated steel C4C



FULL FLOW BALL VALVES: IDEAL

INSTALLATION

The Itap S.p.A.'s valves are bi-directional, that means they manage the flow in both the directions.

The valves are composed by a ball, two seal in PTFE material, one stem, two sailing rings (O-Rings), one handle and a couple of parts made of brass (body and end adapter) that contain them and that are assembled by means of thread and a sealed material to obtain their aim.

In order to avoid that the sealed material gets broken and then the valve loses the connection between the body and the end-adaptor, it's necessary to avoid to submit the two parts under the influence of a torque.

For the installation normal hydraulic practices must be used, and especially:

- ones have to be sure that the two pipes are correctly aligned;
- during the assembling process the installer has to apply its assembling tools at the end that is nearest to the pipe;
- the application of the sealing materials by the fitter (PTFE or hempen cloth) must be limited at the thread zone. An excess should interfere in the ball-gasket's closure zone, compromising the tightness.
- in the case that the fluid transported presents some impurities (dust, water too hard, etc.) ones have to remove these impurities by the means of a filter. Otherwise they could damage the seals.

DISASSEMBLY

To remove the valve from the pipe line or anyhow before to unscrew the junctions linked to it:

- wear the clothing protective normally required to work with the fluid transported within the line;
- depressurize the line and operate in this way:
 - positioning the valve in opened position and then empty the line;
 - handle the valve to put down the residue pressure contained inside the space between the ball and the body before of remove it from the line;
- during the disassembly apply the screw tool at the end of the valve nearest the pipe;

MAINTENANCE

Verify the valve periodically, according to its application's field and its works' field and its work's conditions, in order to be sure that the valve works correctly.



FULL FLOW BALL VALVES: IDEAL

LOSS DIAGRAM (With water)

	3/4"	1"
KV	12	19,2

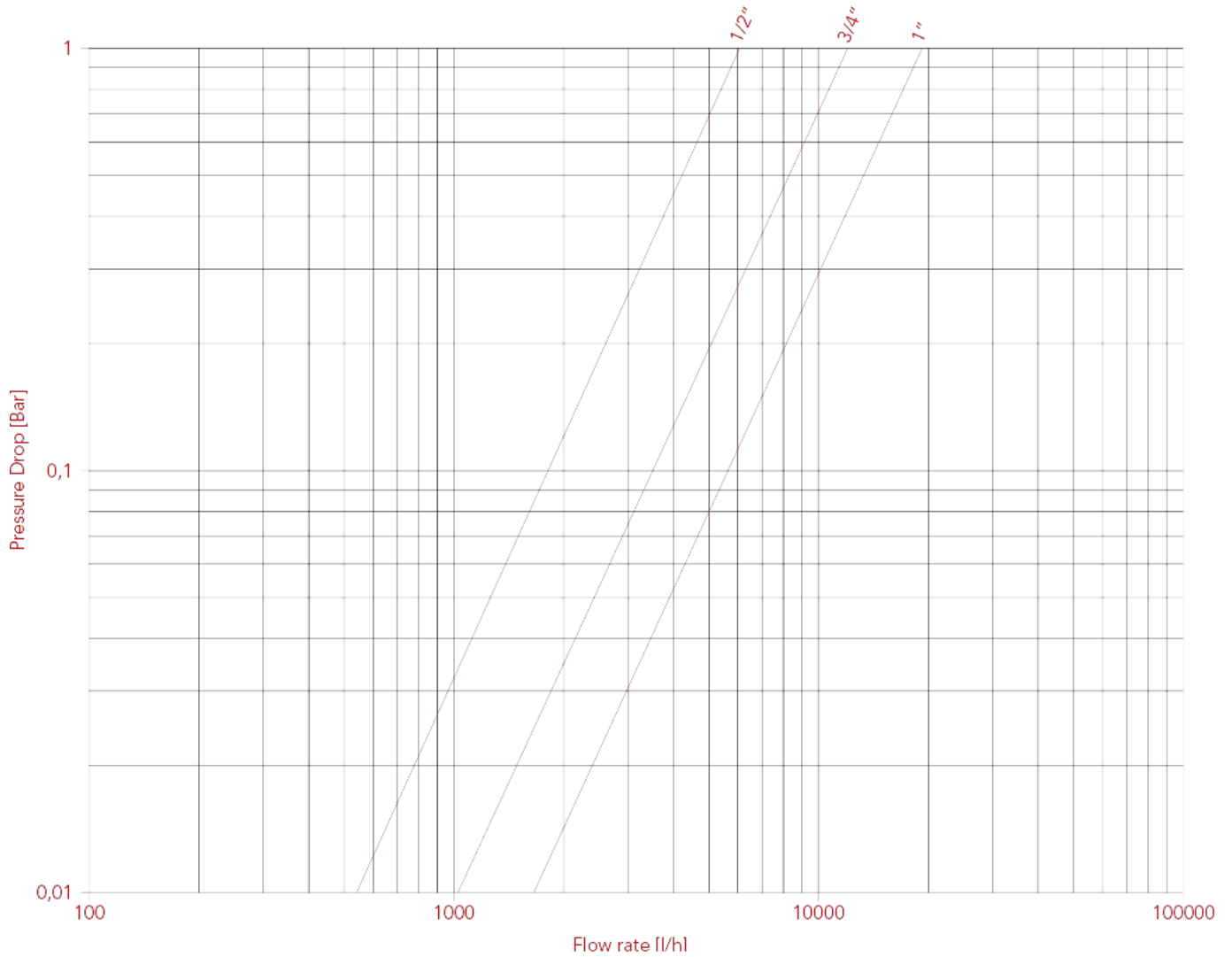



FULL FLOW BALL VALVES: IDEAL

PRESSURE-TEMPERATURE DIAGRAM

The values shown by the dropping lines state the maximum limit of employment of the valves.
The shown values are approximate.

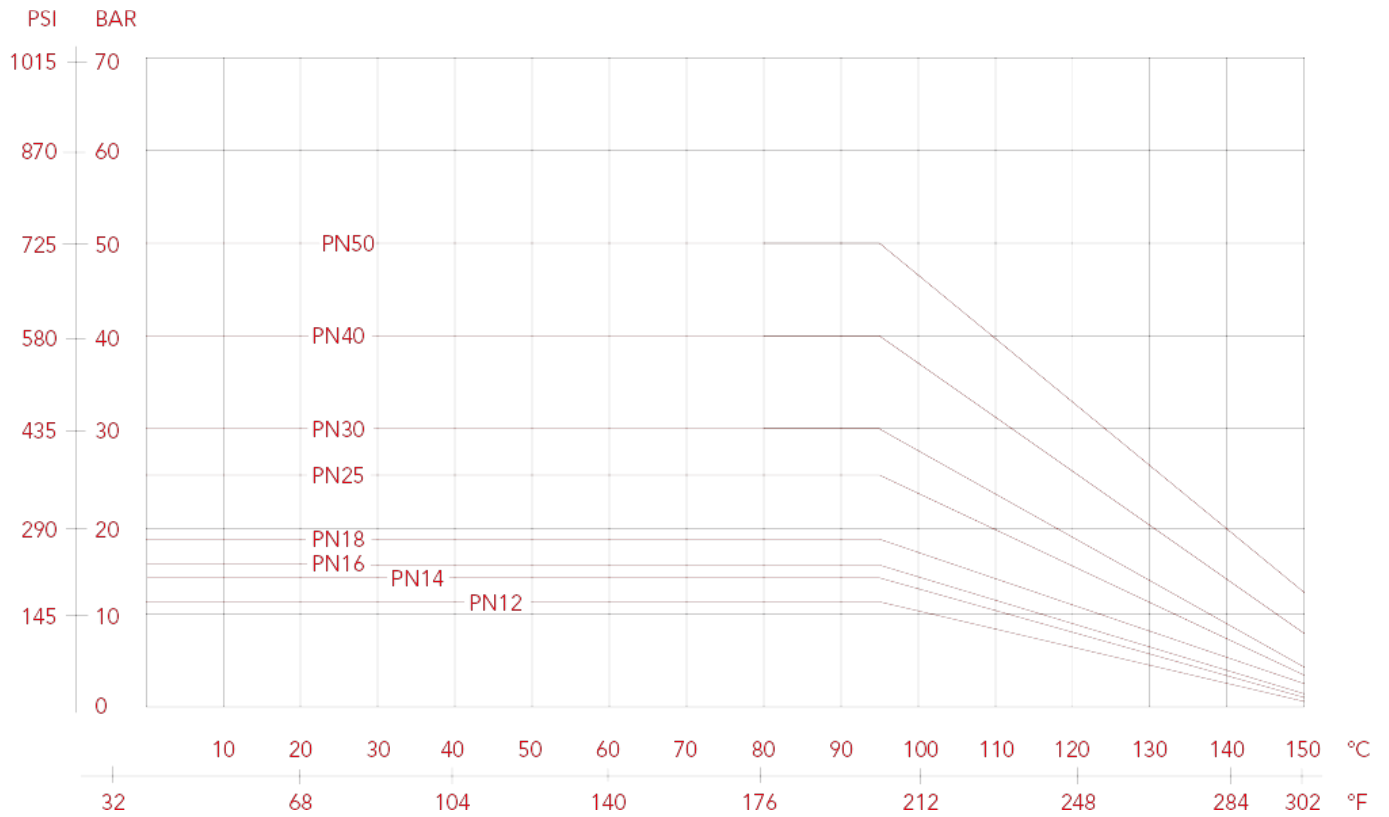



FULL FLOW BALL VALVES: IDEAL

492BC Thermometer union complete with thermometer



SIZE	PRESSURE	CODE	PACKING
1" (DN 25)	10bar/145psi	4920100BC	4/84
1"1/4 (DN 32)	10bar/145psi	4920114BC	4/64

CERTIFICATIONS



TECHNICAL SPECIFICATIONS

Suitable for ball valves art. 098SDC and 298SDC.

Body in nickel-plated brass.

O-ring in NBR.

Thermometer range: 0°C, 80°C.

Diameter: mm.40.

Maximum working temperature: 80°C.

Threads: ISO 228 (equivalent to DIN EN ISO 228 and BS EN ISO 228).

OVERALL DIMENSIONS

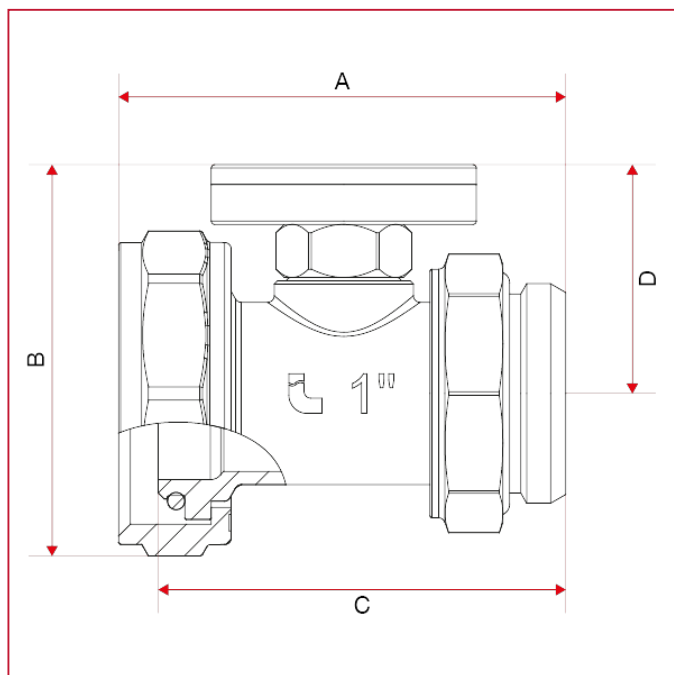



FULL FLOW BALL VALVES: IDEAL

	1"	1"1/4
A	67,5	79,5
B	49	55
C	61,5	73
D	34,5	39
Kg/cm2 bar	10	10
LBS - psi	145	145

MATERIALS size 1"

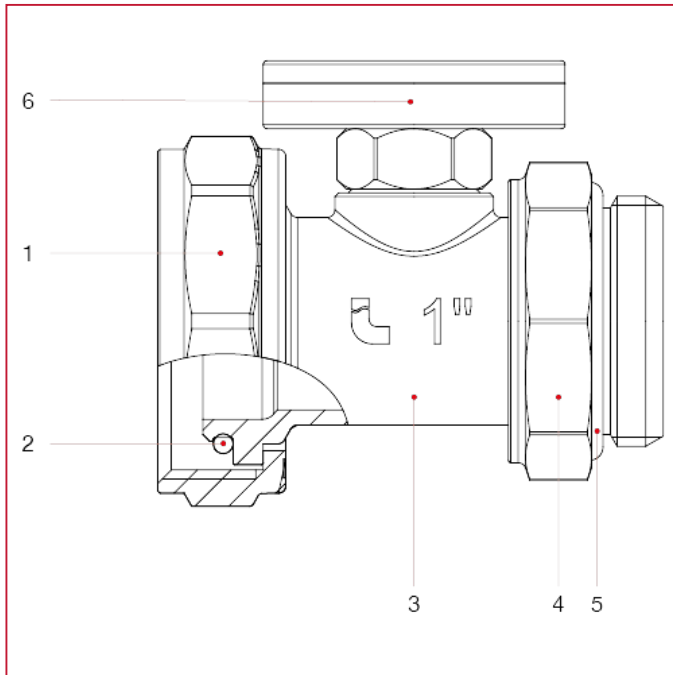

POS.	DESCRIPTION	N.	MATERIAL
1	Nut	1	Nickel-plated brass CW617N
2	O-ring	1	NBR
3	Thermometer fitting	1	Nickel-plated brass CW617N
4	Nut	1	Nickel-plated brass CW617N
5	O-ring	1	NBR
6	Thermometer	1	Brass CW614N



FULL FLOW BALL VALVES: IDEAL

MATERIALS size 1"1/4

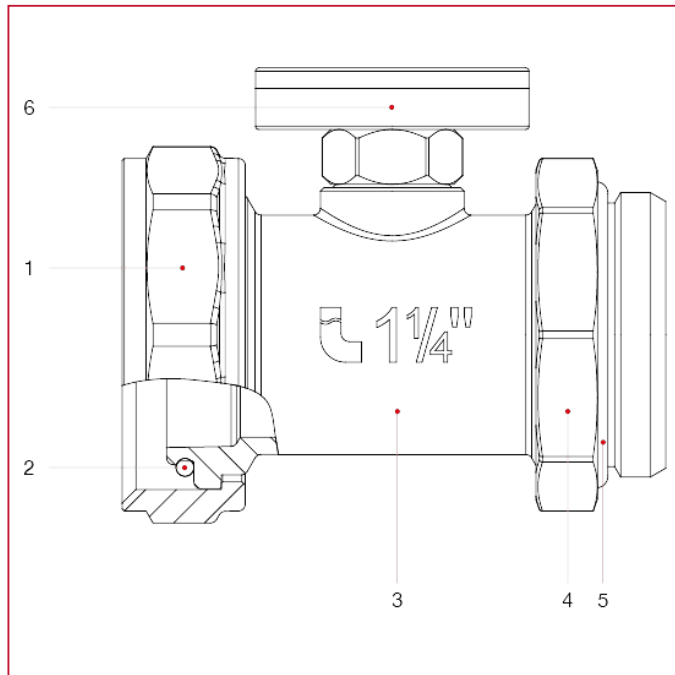

POS.	DESCRIPTION	N.	MATERIAL
1	Nut	1	Nickel-plated brass CW617N
2	O-ring	1	NBR
3	Thermometer fitting	1	Nickel-plated brass CW617N
4	Nut	1	Nickel-plated brass CW617N
5	O-ring	1	NBR
6	Thermometer	1	Brass CW614N



ITAP S.p.A.
Via Ruca 19
25065 Lumezzane
Brescia (ITALY)
Tel 030 8927011
Fax 030 8921990
www.itap.it - info@itap.it

We reserve the right to make improvements and changes to the products described herein and to the relative technical data, at any time and without forewarning.

rev. 20211126