

# METAURO FREE 160 180

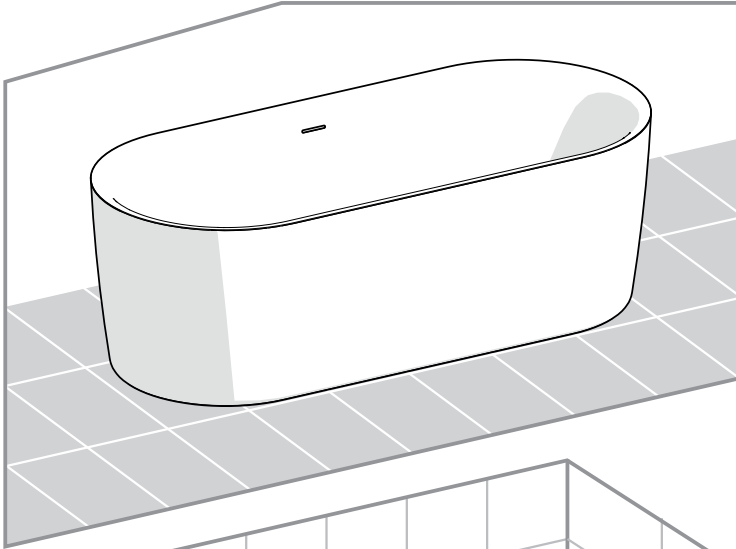

SAMOSTOJEĆA KADA  
*FREISTEHENDE BADEWANNE*  
FREESTANDING BATHTUB  
SAMOSTOJEĆA KOPALNA KAD

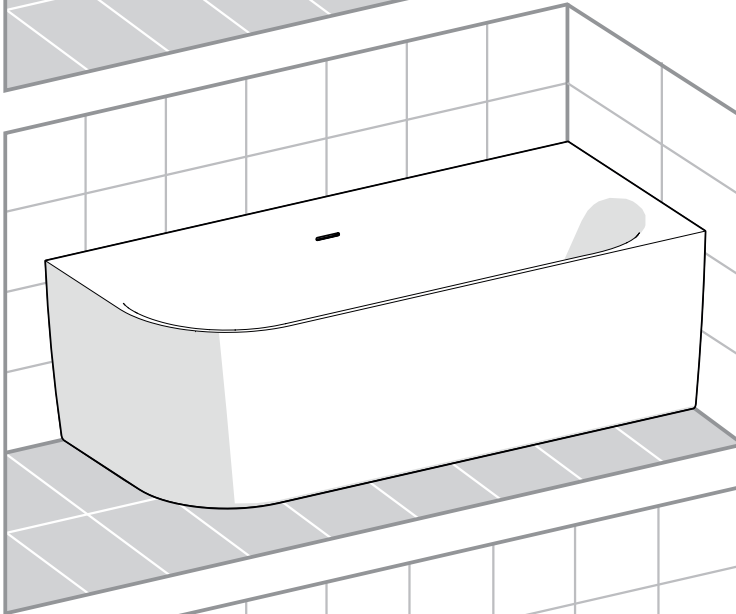

KUTNA KADA L/D  
*ECKWANNE L/R*  
CORNER TUB L/R  
KOTNA KAD L/D

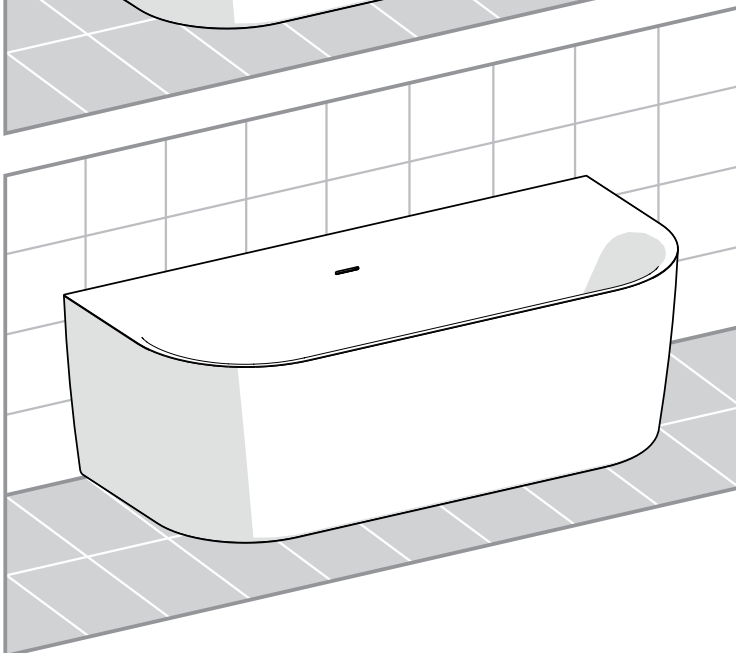

MONTAŽA NA ZID  
*WANDMONTAGE*  
BACK TO WALL  
STENSKA MONTAŽA



min. 2x

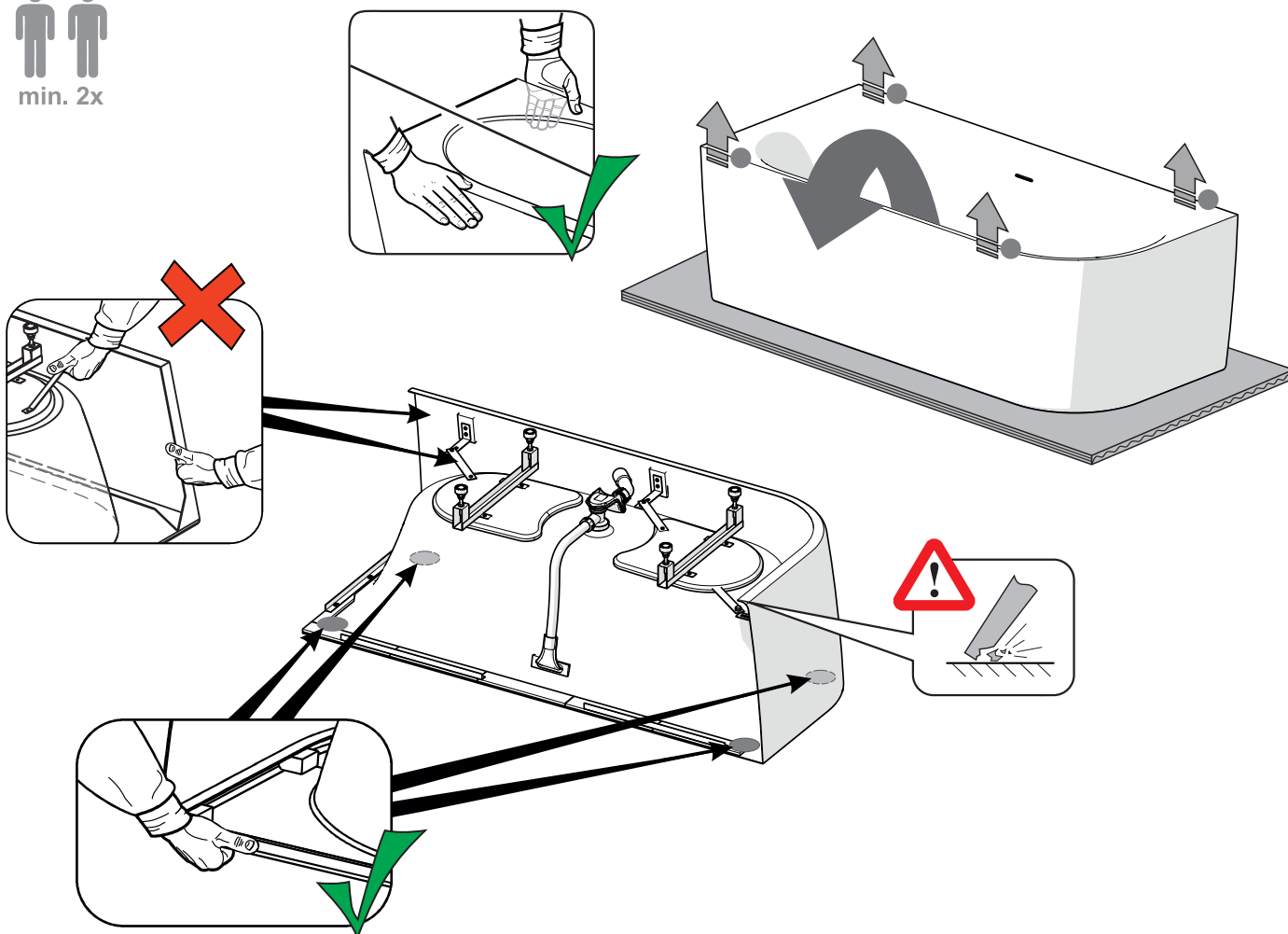

- ▶ U slučaju dužeg vremena manipulacije kadom, tj. potrebe dužeg nošenja kade do mjesta montaže okrenuti kadu naopako i držati je za rub kako je prikazano na slici.
- ▶ Kadu nije dopušteno nositi za bočne stranice niti za šipke koje pridržavaju oblogu uz kadu.
- ▶ Obloga ne smije dodirivati tlo.
- ▶ Kada smije stajati samo na potpornim nogama.
- ▶ Kadu ne smijete gurati ili vući po podu

- ▶ *Bei einer längeren Montagezeit muss die Wanne auf dem oberen Wannenrand und einem ebenen, sauberen Boden aufliegen. Wird die Wanne getragen, ist sie ebenfalls umzudrehen.*
- ▶ *Die Wanne darf nicht an der Schürze oder an den Trägern gehalten bzw. getragen werden.*
- ▶ *Die Schürze darf auf keinen Fall den Boden berühren. Die Wanne darf ausschließlich auf den Trägerfüßen stehen.*
- ▶ *Die Wanne darf nicht über den Boden geschoben oder gezogen werden.*

- ▶ In case of longer manipulation time i.e. longer time of carrying the bath to the building site it is necessary to turn the bath upside down and hold it on the bath's rim.
- ▶ It is not allowed to carry the bath by its side panels nor the bars holding the panel to the frame.
- ▶ The panel must not touch the ground under any circumstances.
- ▶ The tub may only stand on the support feet.
- ▶ The tub must not be pushed or pulled across the floor.

- ▶ V primeru daljše manipulacije s kadjo, to je potrebe po daljšem nošenju kadi do mesta namestitve, obrnite kad na glavo in jo primite za rob kadi, kot je prikazano na sliki.
- ▶ Kopalne kad ni dovoljeno prenašati za stranice ali za prečke, ki držijo oblogo na kadi.
- ▶ Oblogo se ne sme dotikati tal.
- ▶ Kopalne kad sme stati samo na podpornih nogah.
- ▶ Kopalne kad ne potiskajte ali vlecite po tleh.

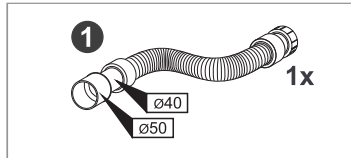
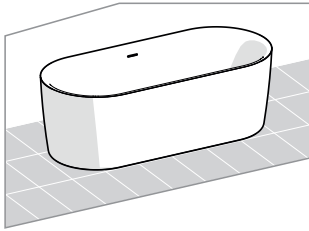

**G $\frac{1}{2}$ "** Samo za kade sa samopunjenjem  
 Nur für selbstfüllende Wannen  
 Only for self-filling tubs  
 Samo za samopolnilne kadi

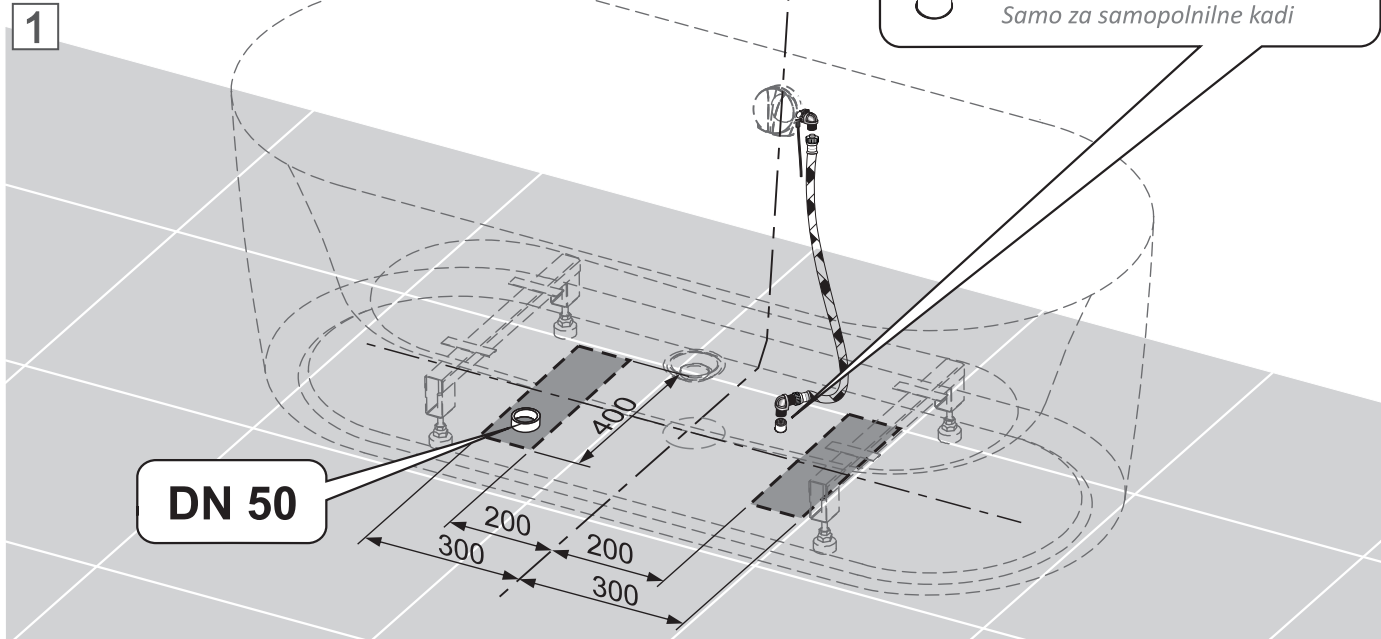

**Dovod vode u kadu izvesti prema projektu vodovodne instalacije, ili prema uputama proizvođača slavine.**  
**Versorgen Sie die Badewanne gemäß dem Projekt der Sanitärinstallation, oder gemäß den Anweisungen des Wasserhahnherstellers.**  
 Supply water to the bathtub according to the project of the plumbing installation, or according to the faucet manufacturer's instructions.  
 Dovod vode v kad po projektu vodovodne inštalacije, ali po navodilih proizvajalca pipe.

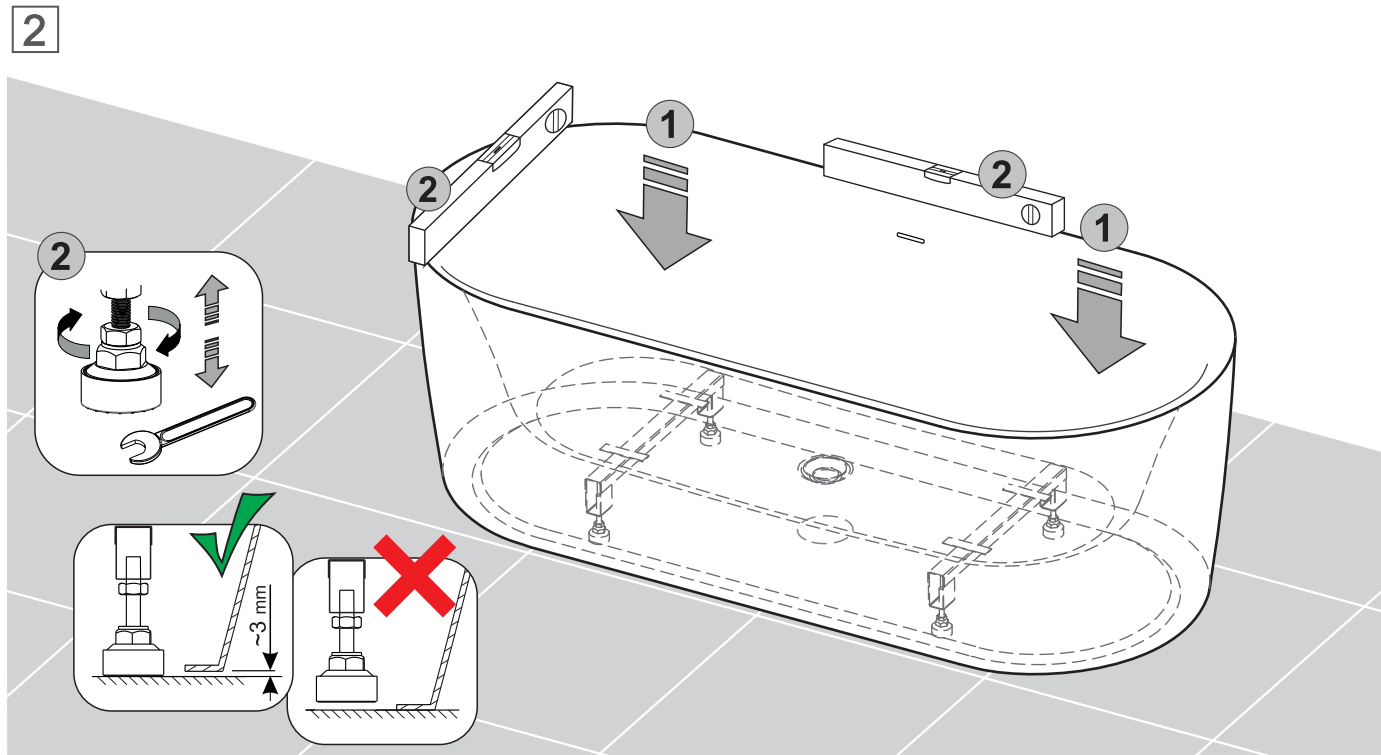

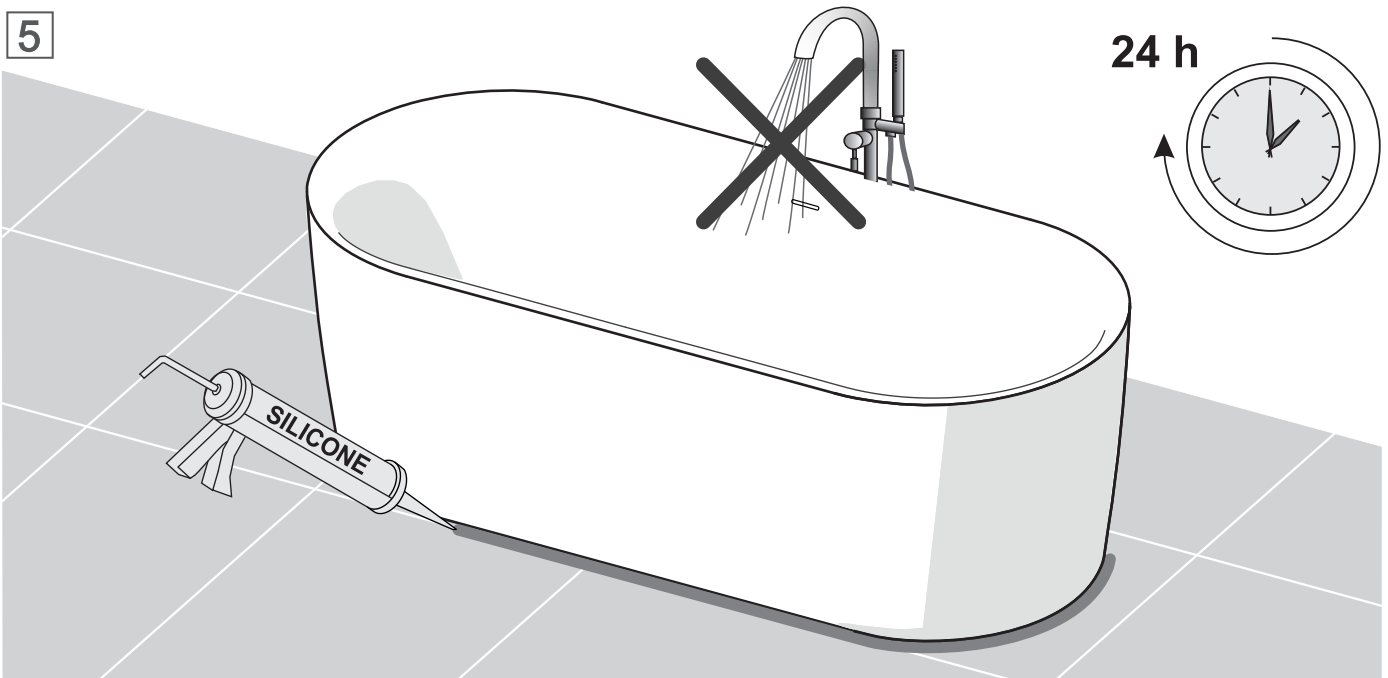
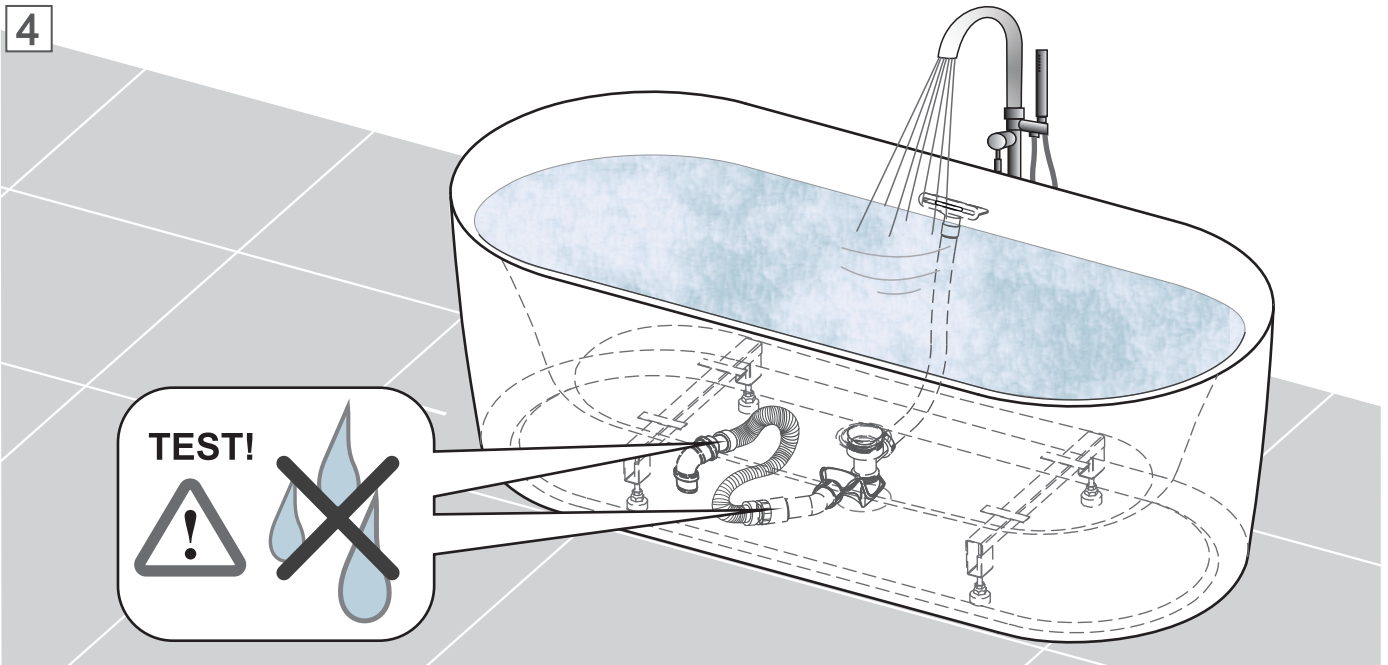
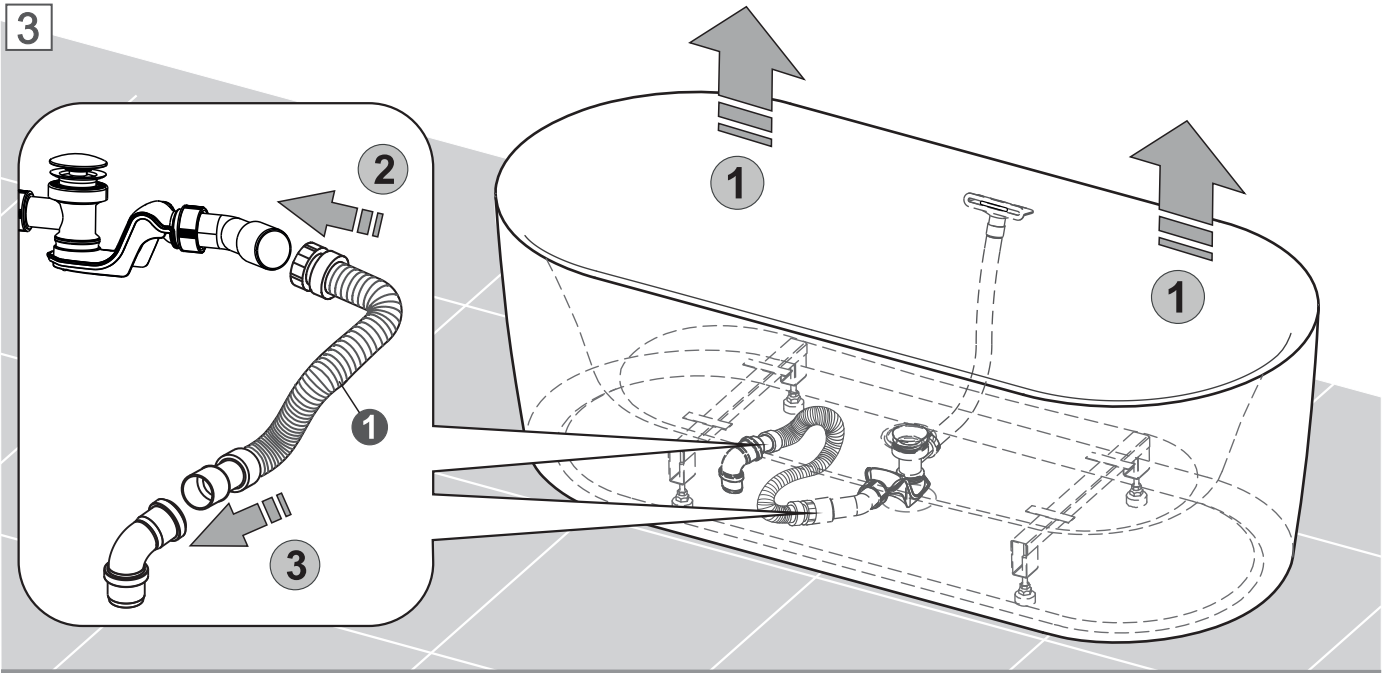

INSTALACIJA VODOVODA I KANALIZACIJE / PLUMBING AND SEWAGE INSTALLATION /  
 SANITÄR- UND ABWASSERINSTALLATION / INŠTALACIJA VODOVODA IN KANALIZACIJE

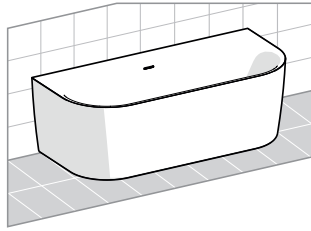
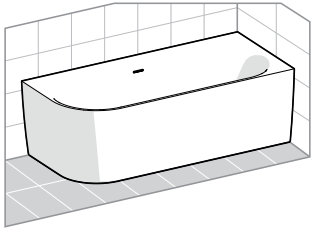

1  8x  
 ø8x50 mm

3  4x

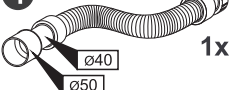
4  1x  
 ø40  
 ø50

2  8x  
 ø5x50 mm

**G<sup>1/2</sup>"** Samo za kade sa samopunjenjem  
 Nur für selbstfüllende Wannen  
 Only for self-filling tubs  
 Samo za samopolnilne kadi

1

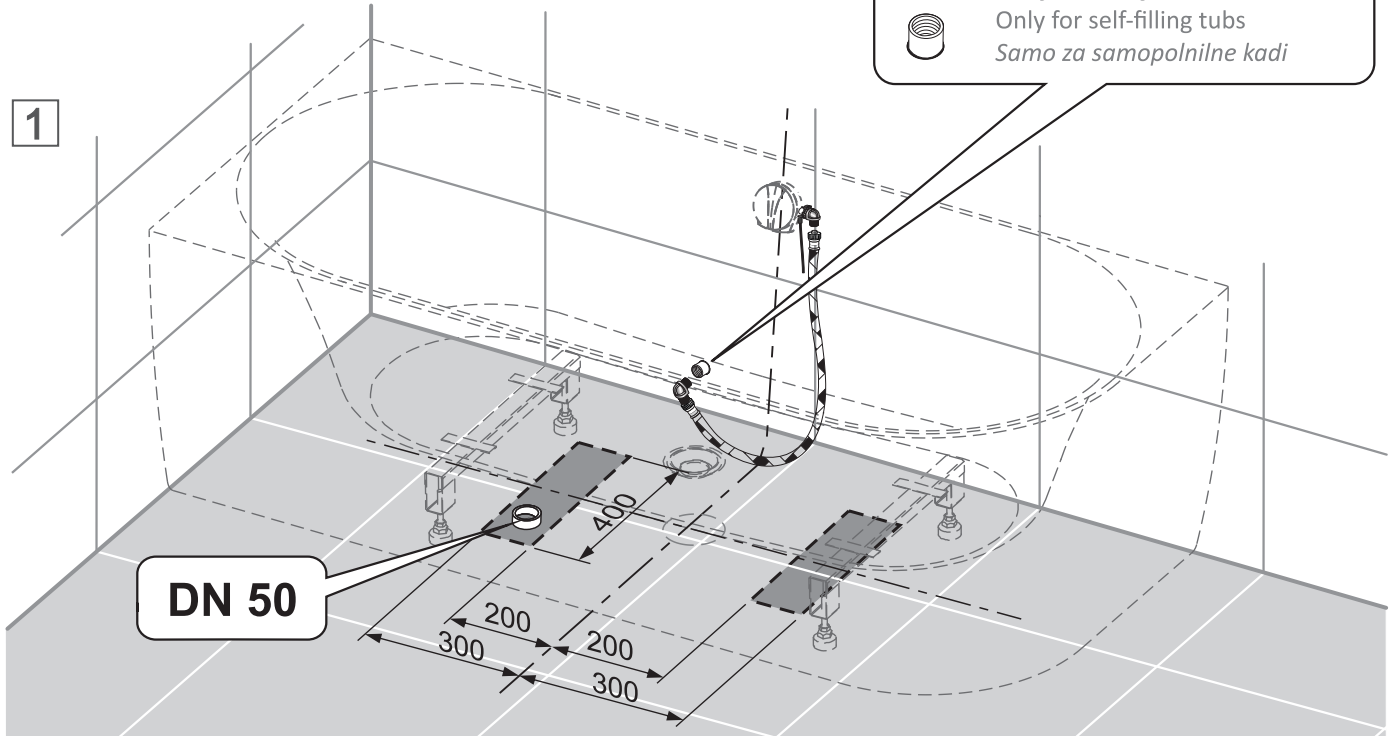

Dovod vode u kadu izvesti prema projektu vodovodne instalacije, ili prema uputama proizvođača slavine.

Versorgen Sie die Badewanne gemäß dem Projekt der Sanitärinstallation, oder gemäß den Anweisungen des Wasserhahnherstellers.

Supply water to the bathtub according to the project of the plumbing installation, or according to the faucet manufacturer's instructions.

Dovod vode v kad po projektu vodovodne inštalacije, ali po navodilih proizvajalca pipe.

2

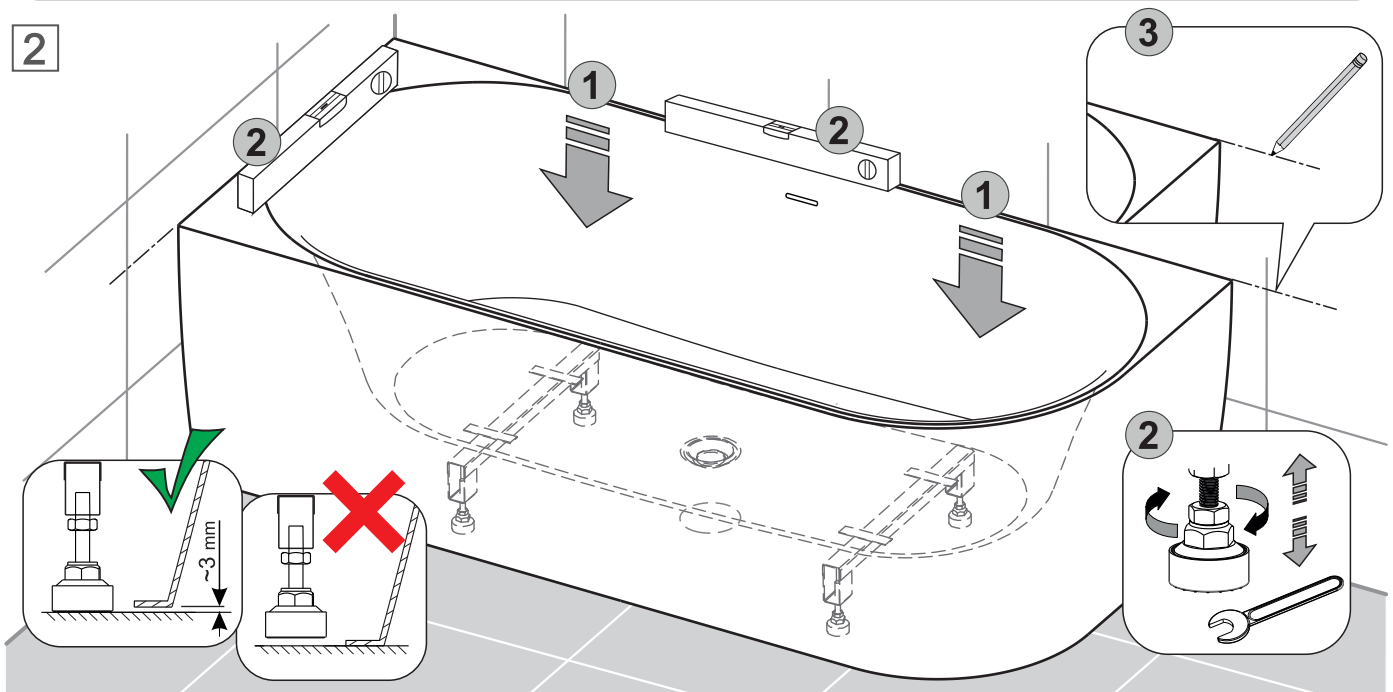

3

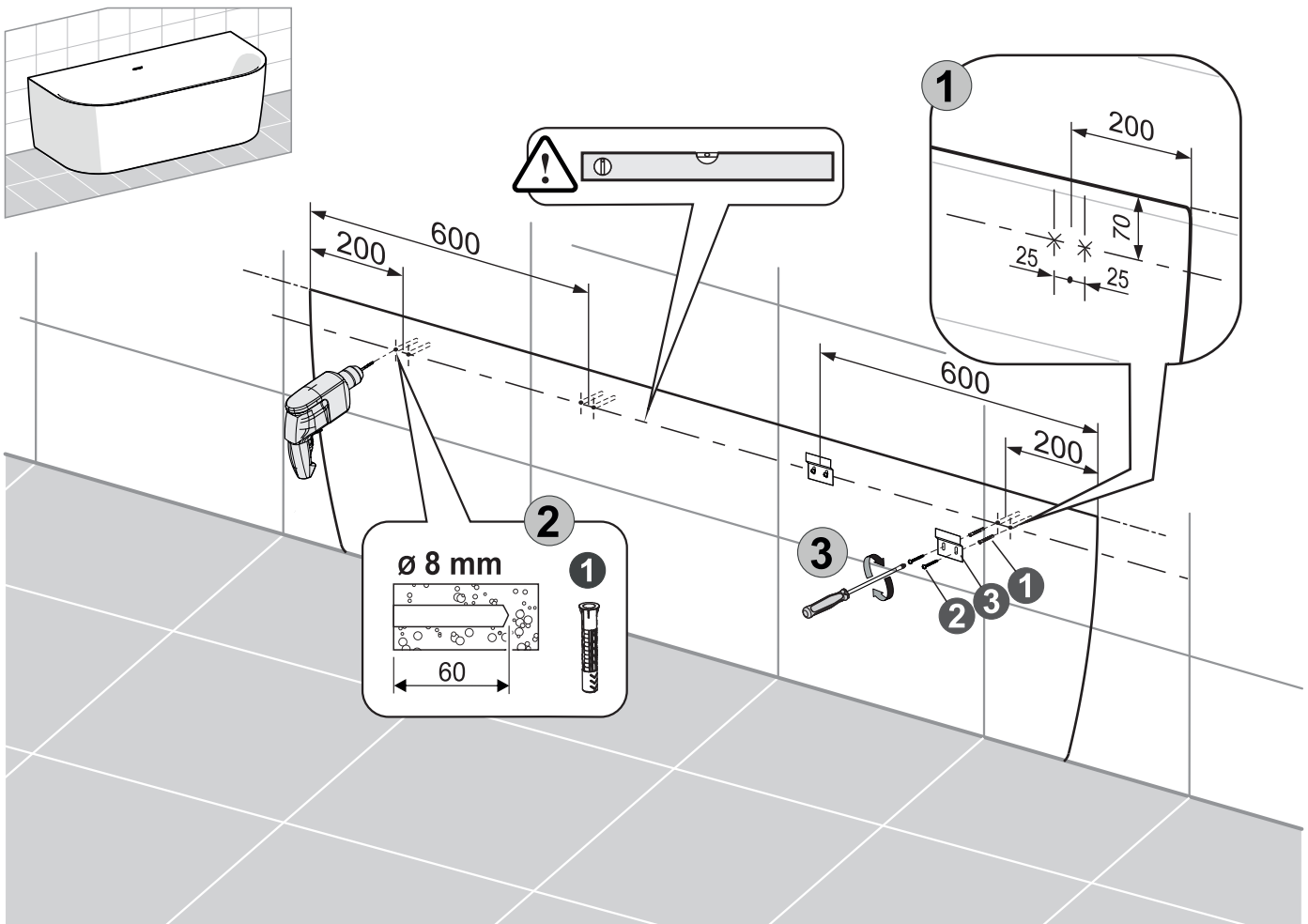
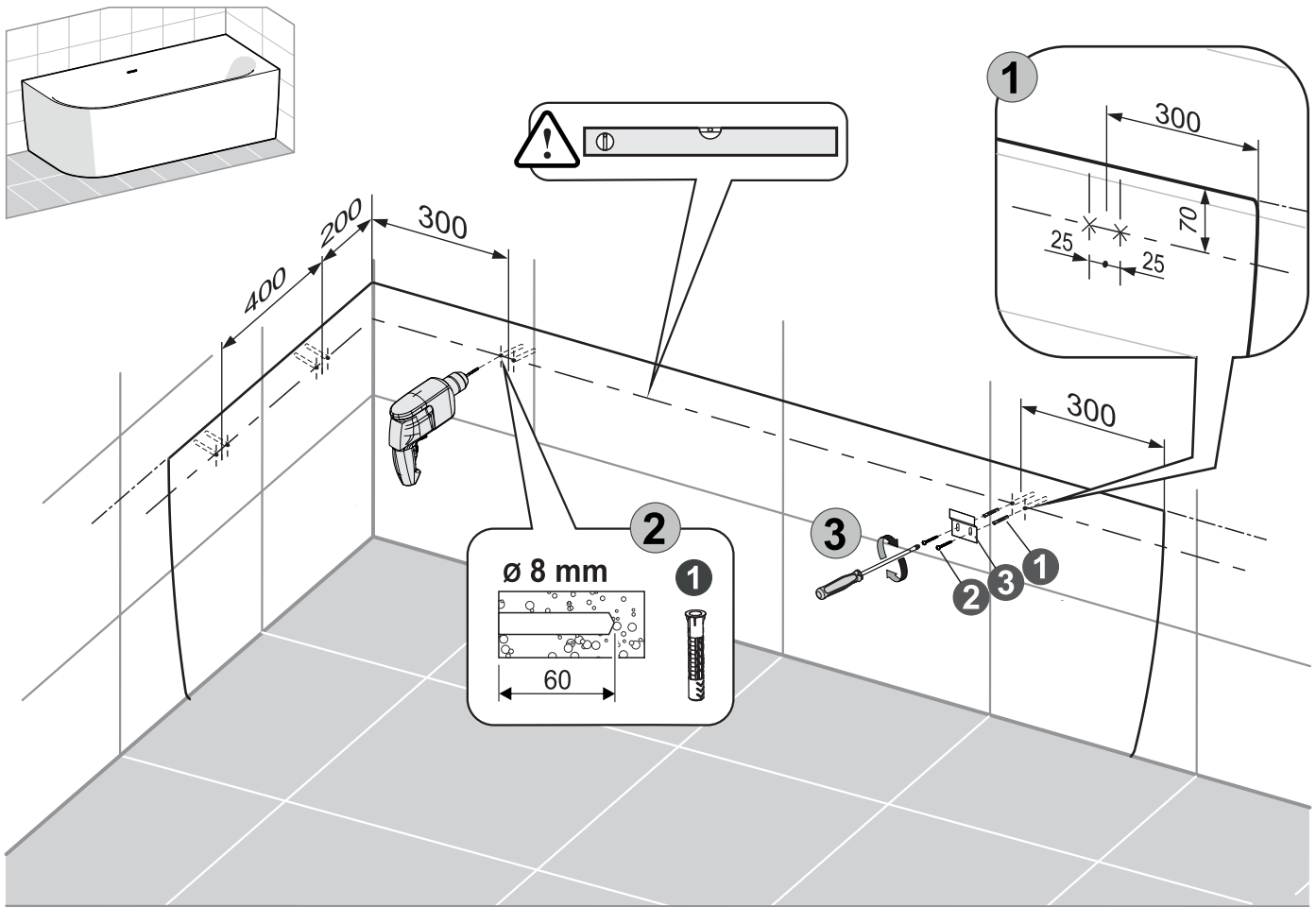

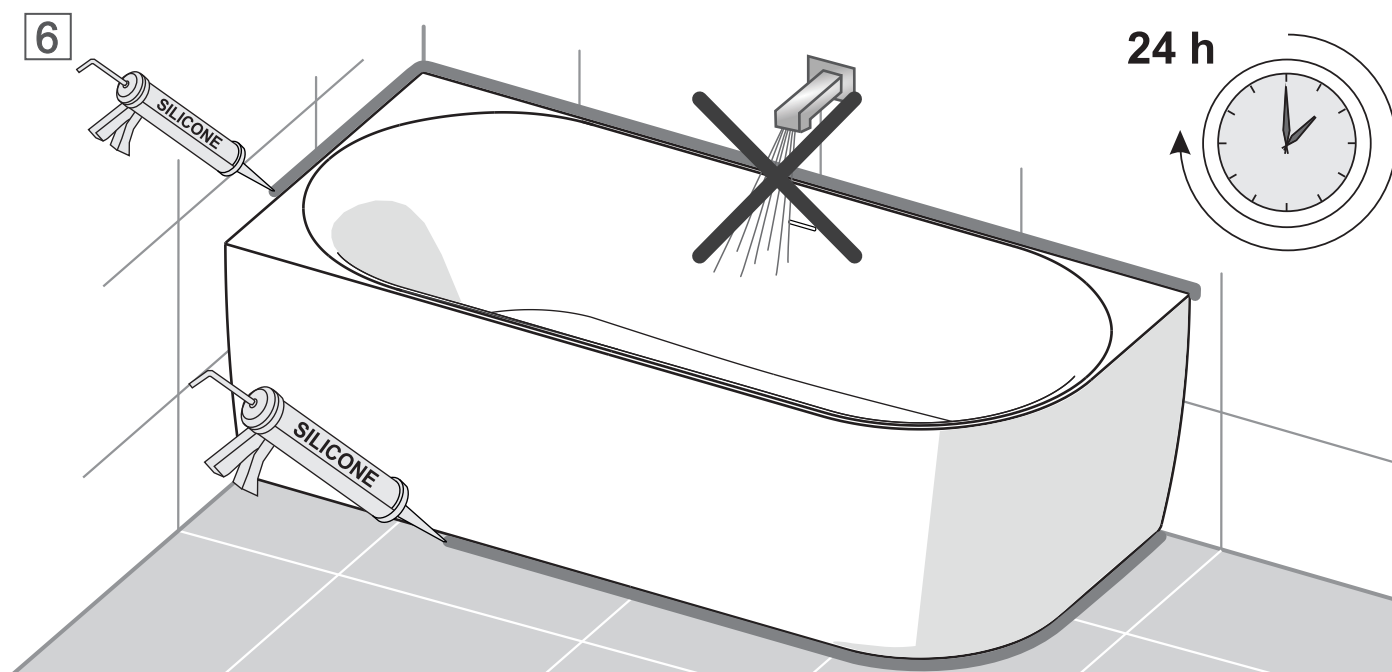
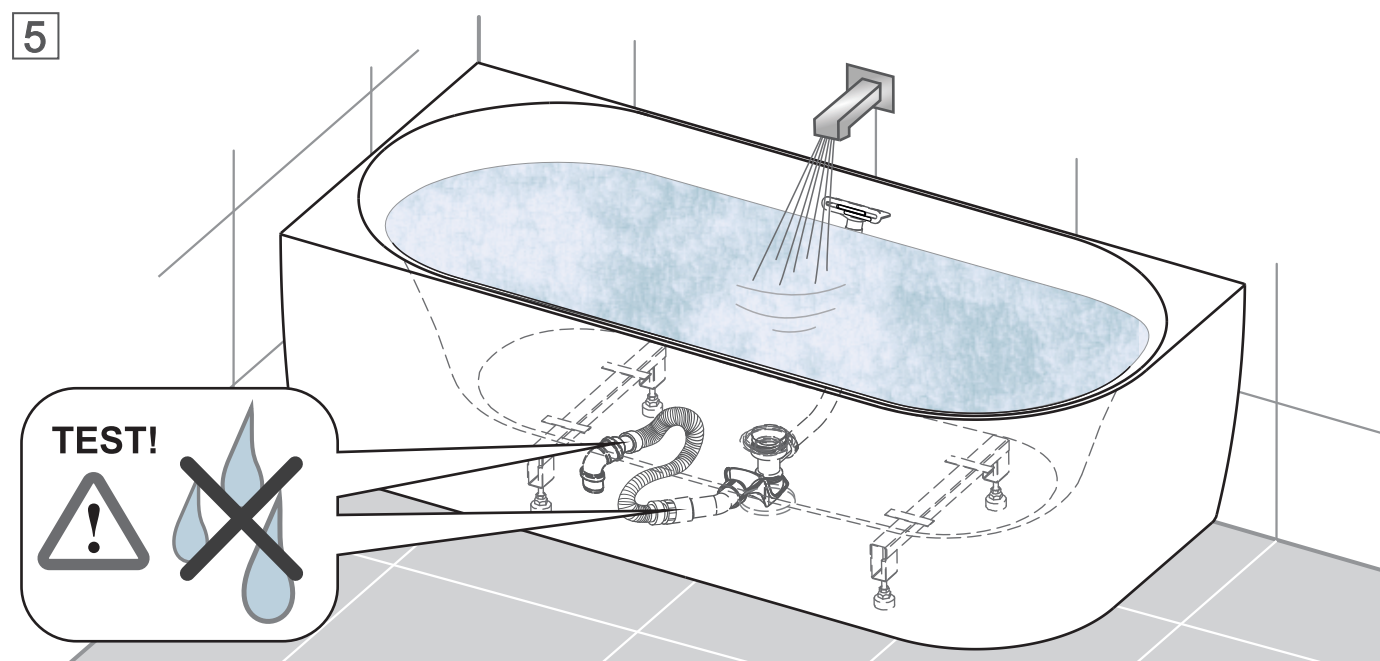
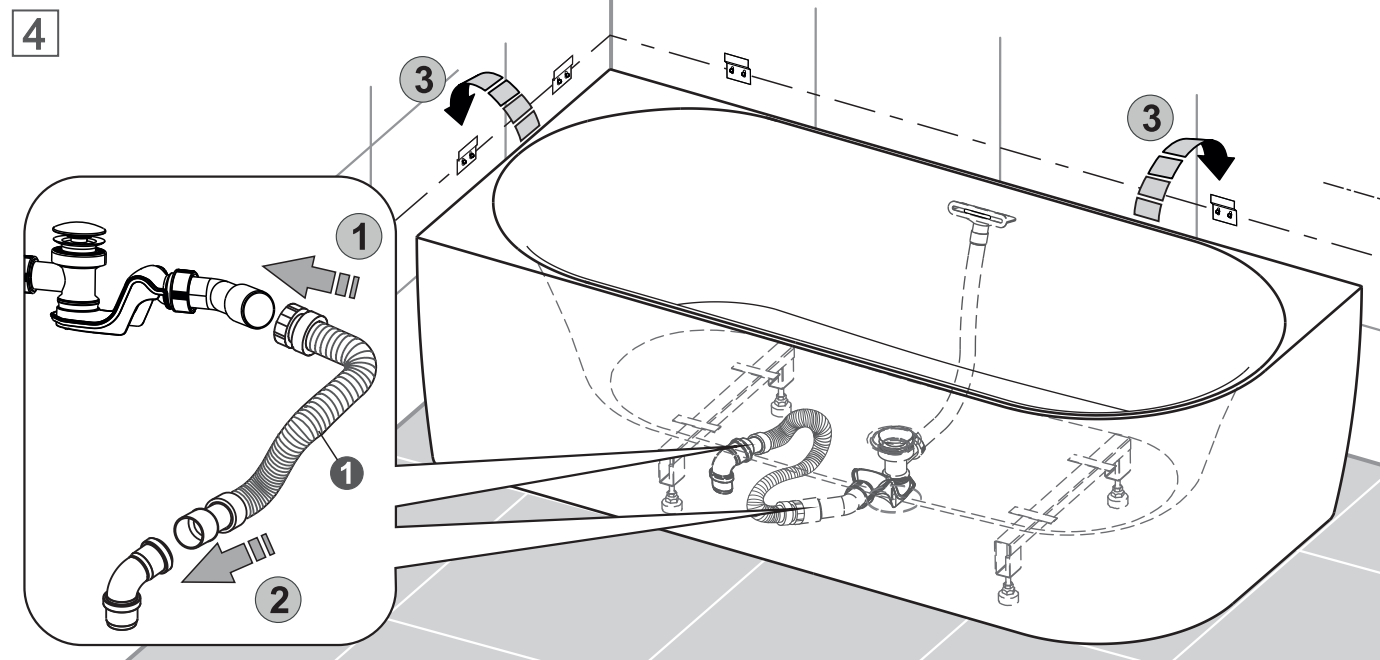

**AQUAESTIL**